

# LAMPKIT20

Lamp socket adaptor kit



## Key features

- Fast and safe connection to lamp sockets
- B22, B14, E27, E14 and GU10 fittings
- Standard 4mm jacks for test equipment
- EN61010-1 CAT II 300V safety rating

The Martindale LAMPKIT20 is supplied with five lamp socket adapters allowing electrical test equipment to be connected via industry standard 4 mm sockets.

The connectors enable a reliable connection for measurement and test purposes, without the need to hold or attach test probes or disassemble the lamp housing.

Included within the kit are adapters for B22, B14, E27, E14 and GU10 standard lamp fittings, a two wire test lead set with 4mm banana plugs and a protective carry case.

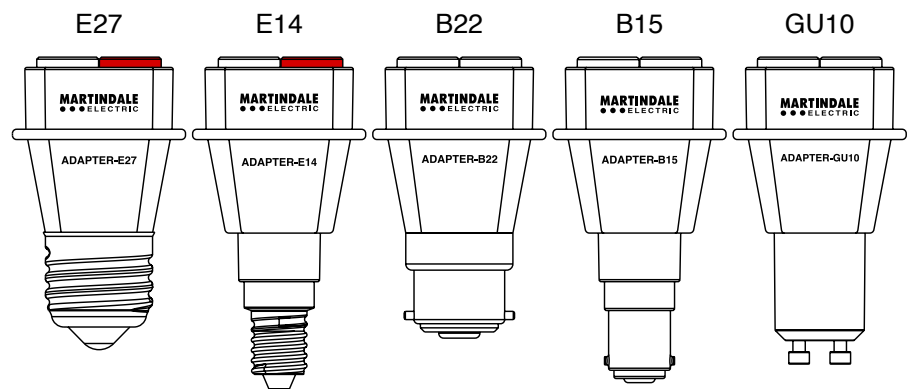



Keeping You Safe

# LAMPKIT20

Lamp socket adaptor kit

Specification

FUNCTION	LAMPKIT20
<b>ELECTRICAL</b>	
Voltage range	0 to 253V AC
Maximum current	2A
Frequency	50Hz
Light fittings supported	B22, B14, E27, E14 and GU10
<b>GENERAL</b>	
Case dimensions	185 x 80 x 105mm
Weight including case	295g
Adaptor dimensions (max)	81 x 42 x 35mm
Adaptor weight (max)	32g
<b>ENVIRONMENTAL</b>	
Location	Indoor & outdoor use in dry weather conditions only
Altitude	up to 2000m
Operating environment	0°C to 40°C at max. 70% Humidity
Storage environment	-20°C to 70°C at max. 80% Humidity
<b>SAFETY</b>	
Conforms to	Conforms to BS EN 61010-1 CAT II 300V
<b>EMC</b>	
Conforms to	BS EN 61326-1

The LAMPKIT20 adaptors are specifically designed for connection of test equipment to standard light fittings. Under no circumstances should the adaptors be used for connection of any other equipment to the mains supply.

Only test leads that are supplied within the kit or those which meet the specific EN61010-1 CAT II 300V safety standard should be used.

**Included**

- B22, B14, E27, E14 and GU10 adaptors
- Test lead set
- Carry case
- Instruction and safety leaflet

Martindale Electric Co. Ltd.  
 Metrohm House, 12 Imperial Park,  
 Imperial Way, Watford WD24 4PP.  
 T: +44 (0)1923 441717  
[www.martindale-electric.co.uk](http://www.martindale-electric.co.uk)  
[sales@martindale-electric.co.uk](mailto:sales@martindale-electric.co.uk)

**Ver. F1.0**

Due to policy of continuous development, Martindale Electric reserves the right to alter equipment specification and description outlined in this document without prior notice. No part of this document shall be deemed to be part of any contract for the equipment unless specifically referred to as an inclusion within such contract. © 2025 Martindale Electric Co. Ltd.