

ET6000 ET6300 ET6500

MULTIFUNCTION INSTALLATION TESTERS

INSTRUCTION MANUAL



MARTINDALE
● ● ● ELECTRIC

Keeping You Safe

TABLE OF CONTENTS

1	Preface	4
<hr/>		
2	Safety & operational considerations	5
2.1	Warnings and meaning of symbols	5
2.2	Batteries	8
2.3	Charging	8
2.4	Precautions on charging new battery cells or cells unused for a longer period	9
2.5	Standards applied	10
<hr/>		
3	Instrument description	11
3.0	Individual model functions	11
3.1	Front panel (depends on model)	12
3.2	Connector panel	13
3.3	Back panel	14
3.4	Bottom view - Information label	16
3.5	Carrying the instrument	16
<hr/>		
4	Instrument operational	17
4.1	Meaning of symbols and messages on the Instrument's display	17
4.2	The online voltage and output terminator monitor	18
4.3	Message field - battery status	18
4.4	Status field - measurement warnings / results symbols	19
4.5	Sound warnings	20
4.6	Performing measurement	20
4.6.1	Measurement function / sub function	20
4.6.2	Selecting measurement function / sub-function	20
4.6.3	Performing tests	20
4.7	Setup menu	21
4.8	Help screen	22
<hr/>		
5	Measurements	23
5.1	Insulation resistance	23
5.2	Continuity	25

5.2.1	R low test	25
5.2.2	Continuity test	28
5.3	Testing RCDs	31
5.3.1	Limit contact voltage	31
5.3.2	Nominal differential trip-out current	31
5.3.3	Multiplier of nominal residual current	31
5.3.4	RCD type and test current starting polarity	31
5.3.5	Testing selective (time-delayed) RCDs	32
5.3.6	Contact voltage	32
5.3.7	Trip-out time	35
5.3.8	Trip-out current	37
5.3.9	Autotest	38
5.3.9.1	How to perform RCD autotest	39
5.4	Fault loop impedance and prospective fault current	44
5.4.1	Fault loop impedance	45
5.4.2	The fault loop impedance test RCD (for RCD protected circuits)	47
5.4.3	The fault loop impedance test R_s (for adjustable current)	48
5.5	Line impedance and prospective short-circuit current	50
5.5.1	Voltage drop test	52
5.6	Phase sequence testing	54
5.7	Voltage and frequency	56
5.8	Earth Resistance	58
5.8.1	Earth Resistance (R_e) - 3-wire, 4-wire	58
5.8.2	Specific earth resistance (R_o)	60
<hr/>		
6	Maintenance	62
6.1	Replacing fuses	62
6.2	Cleaning	62
6.3	Periodic calibration	62
6.4	Service and storage conditions	63
6.5	Batteries	63
<hr/>		
7	Technical specifications	64
7.1	Insulation resistance	64
7.2	Continuity resistance	65
7.2.1	Low R	65
7.2.2	Low current continuity	65

7.3	RCD testing	65
7.3.1	General data	65
7.3.2	Contact voltage	66
7.3.3	Trip-out time	66
7.3.4	Trip-out current	67
7.4	Fault loop impedance and prospective fault current	68
7.5	Line impedance and prospective short-circuit current	70
7.6	Phase rotation	71
7.7	Voltage and frequency	71
7.8	Earth Resistance	72
7.9	General data	73

8	Storing measurements (ET6500)	74
8.1	Overview	74
8.2	Saving results	75
8.3	Recalling results	78
8.4	Deleting results	78

9	Test result download (ET6500 only)	80
9.1	MFT Records - PC software	80
9.2	Downloading records to PC	80

10	Warranty and limitation of liability	81
-----------	---	-----------

11	Measurement categories	82
-----------	-------------------------------	-----------

Check out what other products are available at Martindale

1. PREFACE

Thank you for using a ET6000 series multifunction tester from Martindale. The ET6000 series are professional, multifunctional, hand-held test instruments intended to perform all the measurements required for verification of electrical safety of installations in buildings. The range consists of 3 products, ET6000, ET6300 and ET6500. The ET6300 and ET6500 have the capability for electrical testing of electric vehicle chargers. All three models are covered by this manual.

For safety and a full understanding of the models benefits please read this manual before use.

Technical support is available from +44 (0)1923 44 17 17 and support@martindale-electric.co.uk

The following measurements and tests can be performed:

- Continuity tests,
- Insulation resistance tests,
- RCD testing,
- Line / Loop impedance
- Voltage and frequency,
- Phase rotation,
- Earth resistance (ET6500 only)
- EVSE measurements (ET6300 and ET6500 only)

The large TFT colour display with backlight makes it easy to read results, indications, measurement parameters and messages. The operation of the instrument is designed to be as simple and clear as possible to enable the user to implement testing to the wiring regulations without additional training on operating the tester.

The soft carrying bag, included with the meter, protects the instrument and keeps all accessories together making it simple and easy to move between locations.

2. SAFETY AND OPERATIONAL CONSIDERATIONS

2.1 Warnings and meaning of symbols



REMEMBER: SAFETY IS NO ACCIDENT

These instructions contain both information and warnings that are necessary for the safe operation and maintenance of this product. It is recommended that you read the instructions carefully and ensure that the contents are fully understood. Failure to understand and to comply with the warnings and instructions can result in serious injury, damage or even death.

In order to avoid the danger of electrical shock, it is important that proper safety measures are taken when working with voltages exceeding the extra low voltage (ELV) limit of 50V (25V) AC RMS or 120V (60V) DC. The values in brackets apply to restrictive voltage ranges (for example in the medical or agricultural sector).

This product must only be used by a competent person capable of interpreting the results under the conditions and for the purposes for which it has been constructed. Particular attention should be paid to the Warnings, Precautions and Technical Specifications. Always check the unit is in good working order before use and that there are no signs of damage to it. Do not use if damaged.

Where applicable other safety measures such as use of protective gloves, goggles etc. should be employed.

Particular attention should be paid to the Warnings, Precautions and Technical Specifications.

Please keep these instructions for future reference. Updated instructions, technical support and product information are available at: www.martindale-electric.co.uk

Tel: +44 (0)1923 44 17 17

If this equipment and the accessories supplied are used in a manner not specified by Martindale Electric, the protection provided by the equipment may be impaired.

Only accessories that are supplied and meet the specific characteristics provided by Martindale Electric should be used.

Do not use the probe leads if the wear indicator has become visible.

If a fuse blows in the instrument, follow the instructions in this manual in order to replace it.

Consider all generally known precautions in order to avoid risk of electric shock while dealing with hazardous voltages.

Service intervention or adjustment is only allowed to be carried out by competent authorised personnel.

The ET6300 and ET6500 testers are supplied with rechargeable Ni-MH battery cells. The cells should only be replaced with the same type as defined on the battery compartment label or as described in this manual. Never use standard alkaline battery cells while the power supply adapter is connected.

Hazardous voltages exist inside the instrument. Disconnect all test leads, remove the power supply cable and switch off the instrument before removing the battery compartment cover.

Meaning of symbols and markings



Caution - risk of danger & refer to instructions



Caution - risk of electric shock



Equipment protected by double or reinforced insulation
(Class II)



Do not use in distribution systems with voltages higher than 550V

CAT II (**Measurement Category II**) is applicable to test and measuring equipment connected directly to utilisation points (socket outlets and similar points) of the low-voltage MAINS installation

CAT III (**Measurement Category II**) is applicable to test and measuring equipment connected to the distribution part of the building's low-voltage MAINS installation

CAT IV (**Measurement Category IV**) is applicable to test and measuring equipment connected at the source of the building's low-voltage MAINS installation

For further information on measurement categories refer to page 82, or visit martindale-electric.co.uk/measurement_categories.php



Equipment complies with relevant directives



Equipment complies with relevant UK conformity assessed marking



Direct current (DC)



Alternating current (AC)



End of life disposal of this equipment should be in accordance with relevant directives



WARNINGS RELATED TO MEASUREMENT FUNCTIONS

Insulation resistance

- Insulation resistance measurements should only be performed on de-energized circuits.
- When measuring the insulation resistance between installation conductors, all loads must be disconnected, and all switches closed.
- Do not touch the test circuit during the measurement or before it is fully discharged. Risk of electric shock.
- Do not connect test terminals to external voltage higher than 550 V (AC or DC) in order not to damage the test instrument.

Continuity functions

- Continuity measurements should only be performed on de-energized circuits.
- Parallel impedances or transient currents may influence test results.

Testing PE terminal

- If phase voltage is detected on the tested PE terminal, stop all measurements immediately and ensure the cause of the fault is eliminated before proceeding with any further testing.

NOTES RELATED TO MEASUREMENT FUNCTIONS

General

- The “!” indicator means that the selected measurement cannot be performed because of irregular conditions on input terminals.
- Insulation resistance, continuity functions and earth resistance measurements can only be performed on de-energized circuits.
- PASS / FAIL indication is enabled when limit is set. Apply appropriate limit value for evaluation of measurement results.
- In the case that only two of the three wires are connected to the electrical installation under test, only voltage indication between these two wires is valid.

Insulation resistance

- If voltages of higher than 30V (AC or DC) are detected between test terminals, the insulation resistance measurement will not be performed.

Continuity functions

- If voltages higher than 10V (AC or DC) are detected between test terminals, the continuity resistance test will not be performed.
- Before performing a continuity measurement, where necessary, compensate for test lead resistance.

RCD functions

- Parameters set in one function are also kept for other RCD functions.
- The measurement of contact voltage does not normally trip an RCD. However, the trip limit of the RCD may be exceeded because of leakage current flowing to the PE protective conductor or a capacitive connection between L and PE conductors.
- The loop impedance RCD sub-function (function selector switch in LOOP position) takes longer to complete but offers much better accuracy of fault loop resistance (in comparison to the RL sub-result in Contact voltage function).
- RCD trip out time and RCD trip out current measurements will only be performed if the contact voltage in the pre-test at nominal differential current is lower than the set contact voltage limit.
- The auto-test sequence (RCD AUTO function) stops when trip-out time is out of the allowable time period.

Loop impedance (with Loop RCD and / or Loop Rs option)

- I_{sc} depends on Z , U_n and scaling factor
- The current limit depends on fuse type, fuse current rating, fuse trip-out time.
- The specified accuracy of tested parameters is valid only if the mains voltage is stable during the measurement.
- Fault loop impedance measurements will trip an RCD.
- The measurement of fault loop impedance using the loop impedance RCD function does not normally trip an RCD. However, the trip limit may be exceeded as a result of leakage current flowing to the PE protective conductor or a capacitive connection between L and PE conductors.

Line impedance

- Isc depends on Z, Un and scaling factor.
- The current limit depends on fuse type, fuse current rating and fuse trip-out time.
- The specified accuracy of tested parameters is valid only if the mains voltage is stable during the measurement.

2.2 Batteries

When connected to an installation, the instruments battery compartment can contain hazardous voltages. Before opening the battery/fuse compartment cover, disconnect any measuring accessory connected to the instrument and turn off the instrument.

- Ensure that the battery cells are inserted correctly otherwise the instrument will not operate and the batteries could be discharged.
- If the instrument is not to be used for a long period of time, remove all batteries from the battery compartment.
- Rechargeable Ni-MH batteries (size AA) can be used. It is recommended only using rechargeable batteries with a capacity of 2300mAh or above.
- Do not attempt to recharge alkaline battery cells.

2.3 Charging

The batteries will begin charging whenever the power supply adapter is connected to the instrument. The built-in protection circuits control the charging procedure and help achieve maximum battery lifetime. The power supply socket polarity is shown in figure 2.1.



Figure 2.1: Power supply socket polarity

Note:

Only use the Martindale power supply adapter supplied with the product or equivalent Martindale supplied accessory to avoid possible fire or electric shock.

2.4 Precautions on charging of new battery cells or cells unused for a longer period

Unpredictable chemical processes can occur during the charging of new battery cells or cells that have been left unused for long periods of time (more than 3 months).

When using an external intelligent battery charger, one complete discharging/charging cycle can be performed automatically. After performing this procedure, normal battery capacity should be fully restored, and the operating time of the instrument will approximately meet the data set out in the technical specification.

Notes:

- The charger supplied with the ET6300 and ET6500 is a pack cell charger. This means that the cells are connected in series during the charging so all of them must be in similar state (similarly charged, same type and age).
- A deteriorated battery cell (or one of a different type e.g. capacity, chemical design) can disrupt charging of the entire battery pack which could lead to overheating and a significant decrease in the operating time.
- If no improvement is achieved after performing several charging/discharging cycles, the state of each individual battery cell should be determined (by comparing battery voltages, checking them in a cell charger, etc). It is very likely that one or more of the battery cells could have deteriorated.
- The effects described above should not be confused with the normal battery capacity decrease over time. All re-chargeable batteries lose some of their capacity when repeatedly charged/discharged. The actual decrease in capacity compared to the number of charging cycles depends on the battery type. This information is normally provided in the technical specification from battery manufacturer.

2.5 Standards applied

The Martindale ET6000 Series instruments are manufactured and tested in accordance with the following directives:

Electromagnetic compatibility (EMC)

BS EN 61326	Electrical equipment for measurement, control and laboratory use – EMC requirements Class B (Hand-held equipment used in controlled EM environments)
-------------	--

Safety (LVD)

BS EN 61010-1	Safety requirements for electrical equipment for measurement, control and laboratory use – Part 1: General requirements Class B (Hand-held equipment used in controlled EM environments)
BS EN 61010-031	Safety requirements for hand-held probe assemblies for electrical measurement and test

Functionality

BS EN 61557	Electrical safety in low voltage distribution systems up to 1000 VAC and 1500 VDC – Equipment for testing, measuring or monitoring of protective measures Part 1 General requirements Part 2 Insulation resistance Part 3 Loop resistance Part 4 Resistance of earth connection and equipotential bonding Part 5 Resistance to earth Part 6 Residual current devices (RCDs) in TT and TN systems Part 7 Phase sequence Part 10 Combined measuring equipment
-------------	---

EVSE

IEC 62955	Residual direct current detecting device (RDC-DD) to be used for mode 3 charging of electric vehicles
-----------	---

Note about EN and IEC standards:

Text of this manual contains references to UK and European standards. All standards BS EN 6XXXX (e.g. BS EN 61010) series are equivalent to IEC standards with the same number (e.g. IEC 61010) and differ only in amended parts required by European and UK harmonization procedures.

3. INSTRUMENT DESCRIPTION

3.0 Individual model functions

Model	ET6000	ET6300	ET6500
SPECIFICATION			
Voltage	0V - 500V		
Frequency	10HZ - 499HZ		
EV ready		✓	✓
Complies with	BS EN 61010-1 CAT III 600V CAT IV 300V BS EN 61557, BS 57671:2018 18th Edition BS EN 61326-1		
Dimensions	250mm x 107mm x 135mm		
Weight	1.3kg approx (excluding battery)		
INSULATION RESISTANCE			
Nominal voltages 50, 100, 250, 500 and 1,000V DC	✓	✓	✓
CONTINUITY RESISTANCE			
Low R (200mA)	✓	✓	✓
Continuity (low current)		✓	✓
RCD TESTING			
Nominal residual currents (mA)	10 / 30 / 100 / 300 / 500	6 / 10 / 30 / 100 / 500 / 650 / 1000	6 / 10 / 30 / 100 / 500 / 650 / 1000
Test current shape	A, AC	A, AC, B, B+, F	A, AC, B, B+, F
RCD type	G, S	G, S	G, S
Contact voltage	✓	✓	✓
Trip-out time	✓	✓	✓
Trip-out current	✓	✓	✓
FAULT LOOP IMPEDENCE AND PROSPECTIVE FAULT CURRENT			
Z loop L-PE Ipf	✓	✓	✓
Z loop L-PE RCD, Ipf, non-trip subfunction	✓	✓	✓
Loop-Rs		✓	✓
Line impedance and prospective short-circuit current	✓	✓	✓
Voltage drop detection		✓	✓
EARTH RESISTANCE (Requires optional Martindale ER2KIT-S or Martindale ER4KIT-S Earth Spike Kit)			
Re (3-wire and 4-wire) 1Ω / 9999Ω			✓
Ro (Specific earth resistance testing)			✓
OTHER FEATURES			
Automatic polarity change		✓	✓
Calibration date reminder	✓	✓	✓
Memory and reporting (Excel-export)			✓
Rechargeable batteries suitable for on-board charging	Optional	✓	✓
Networks	TN, TT	TT, TN, IT, LV (2 x 55V)	TT, TN, IT, LV (2 x 55V)
Supplied with external probe with button		✓	✓
Compatible with external probe with button	✓	✓	✓
Supplied with TL305EV adapter		Optional	✓
4mm leads - straight plugs	✓		
4mm leads - stackable plugs		✓	✓

3.1 Front panel (dependent on model, ET6500 shown)

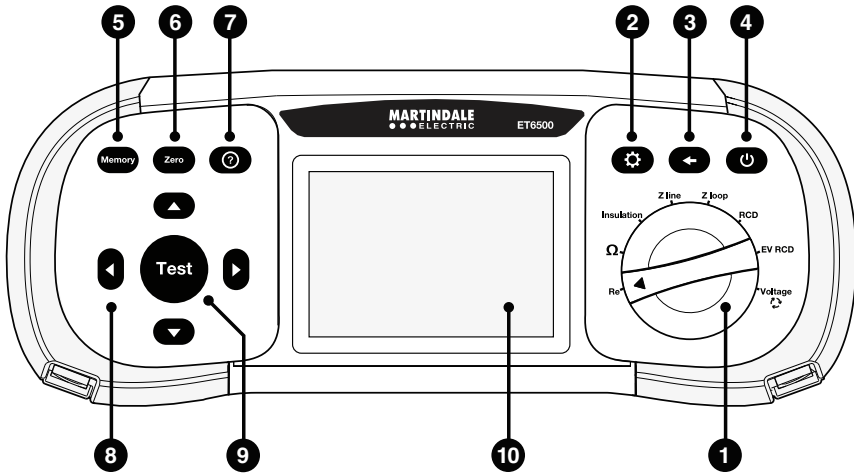

Figure 3.1: Front panel

Legend:

1. Function selector switch
2. Setup key
3. Exit/Back/Return key
4. ON/OFF key, to switch the instrument on and off. The instrument will automatically power off (APO) after the last key press and no voltage is applied. APO time adjustable in settings.
5. Memory key
6. Zero/Null key, to compensate for the test lead resistance in low-value resistance measurements
7. (?) Help key
8. Navigation keys
9. TEST key for starting / confirmation tests
10. TFT colour display

3.2 Connector panel (dependent on model)

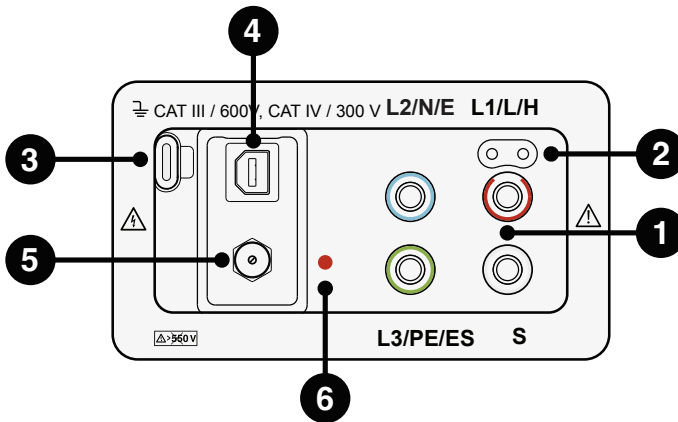

Figure 3.2: Connector panel

Legend:

1. Test connector –
Warning: Maximum allowed voltage between test terminals and ground is 600V.
Maximum allowed voltage between test terminals is 550V
2. Socket for probe with Test push button
3. USB 3 connector (Calibration use only)
4. USB B connector for data transfer (ET6500 only)
5. Battery charger input
6. Charging LED

3.3 Back panel

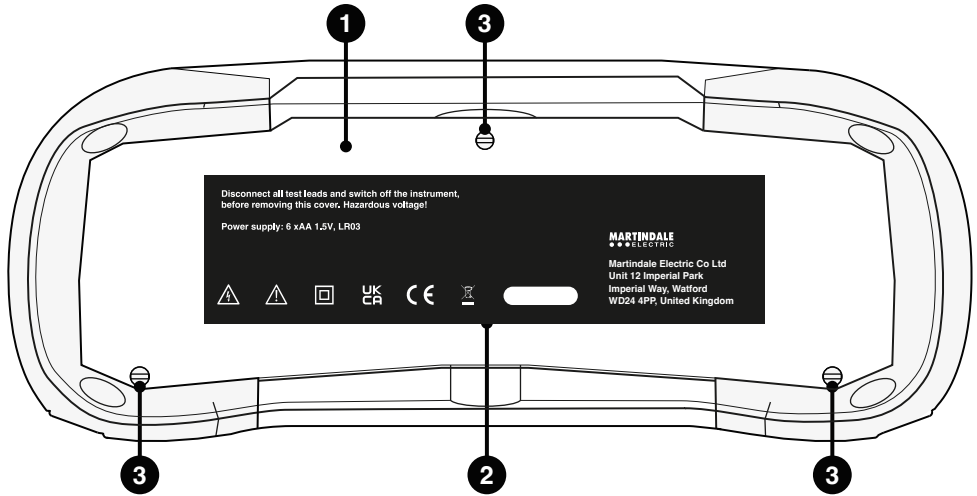

Figure 3.3: Back panel

Legend:

1. Battery / fuse compartment cover
2. Information label
3. Fixing screws for battery / fuse compartment cover

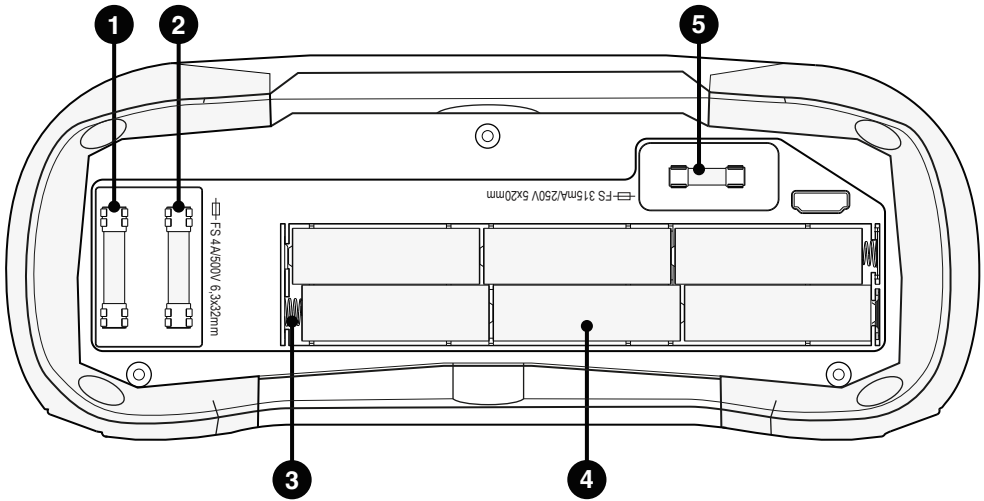

Figure 3.4: Back panel cover removed

Legend:

1. Fuse F1 – 4A 500V 6.3 x 32mm HRC
2. Fuse F2 – 4A 500V 6.3 x 32mm HRC
3. Battery contacts
4. Battery cells (size AA)
5. Fuse F3 - 315mA 250V 5 x 20mm HRC

3.4 Bottom view - Information label

Function	EN61557	Range	Accuracy	Notes
Continuity	-4	0.1 Ω ... 20.0 Ω 0.1 Ω ... 1999 Ω	$\pm(3\%$ of read. + 3 digits) $\pm(5\%$ of read. + 3 digits)	Test current min. 200mA at 2 Ohm Test current max. 7 mA Open circuit voltage 5V
Insulation resistance	-2	0.1 M Ω ... 199.9 M Ω 0.1 M Ω ... 199.9 M Ω 200 M Ω ... 999 M Ω	$\pm(5\%$ of read. + 3 digits) $\pm(2\%$ of read. + 3 digits) $\pm(10\%$ of read.)	50 / 100 / 250V 500 / 1000V max. 15mA
RCD Time Current	-6	0.0 ... 500ms 0.2xI Δ N ... 1.1xI Δ N (AC) 0.2xI Δ N ... 1.5xI Δ N (A), (I Δ N \geq 30 mA) 0.2xI Δ N ... 2.2xI Δ N (A), (I Δ N <30 mA)	± 3 ms $\pm 0.1 \times I \Delta N$	I Δ N 6,10,30,100,300, 500,650,1000mA
Contact voltage		0.2xI Δ N ... 2.2xI Δ N (B) 3V ... 99.9V	(-0%/+10%) of read. +5 digits	
Impedance	-3	0.25 Ω ... 9999 Ω 0.25 Ω ... 9999 Ω 0.75 Ω ... 19.99 Ω 20 Ω ... 9999 Ω	$\pm(5\%$ of read. + 5 digits) $\pm(5\%$ of read. + 5 digits) $\pm(5\%$ of read. + 10 digits) $\pm(10\%$ of read.)	Z line L-L, L-N Z loop L-PE Z loop L-PE non-trip Line: 93V-134V; 185V-266V; 321V-485V; 45Hz-65Hz Loop: 93V-134V; 185V-266V; 45Hz-65Hz
Voltage Frequency	-7	0 ... 550V (45-400Hz) 10.0 ... 499.9Hz	$\pm(2\%$ of read. + 2 digits) $\pm(0.2\% + 1$ digits)	TRMS
Phase rotation	-7	50 ... 550VAC 45 ... 400Hz		Clockwise: 1-2-3 Anticlockwise: 3-2-1
Earth resistance	-5	1.0 Ω ... 9999 Ω 6 Ω ... 9999 Ω	$\pm(5\%$ of read. + 5 digits)	3-wire, 4-wire Specific earth resistance f=126.9

Figure 3.5: Bottom panel information label

3.5 Carrying the instrument

The neck strap supplied as standard with all models allows the instrument to be carried in a variety of different ways. The operator can choose the most appropriate method based on the tasks they are performing.

The instrument can be hung around operator's neck allowing the instrument to move freely. This allows equipment to be moved quickly between test locations.

4. INSTRUMENT OPERATION

4.1 Meaning of symbols and messages on the instrument display

The instrument display is divided into several sections:

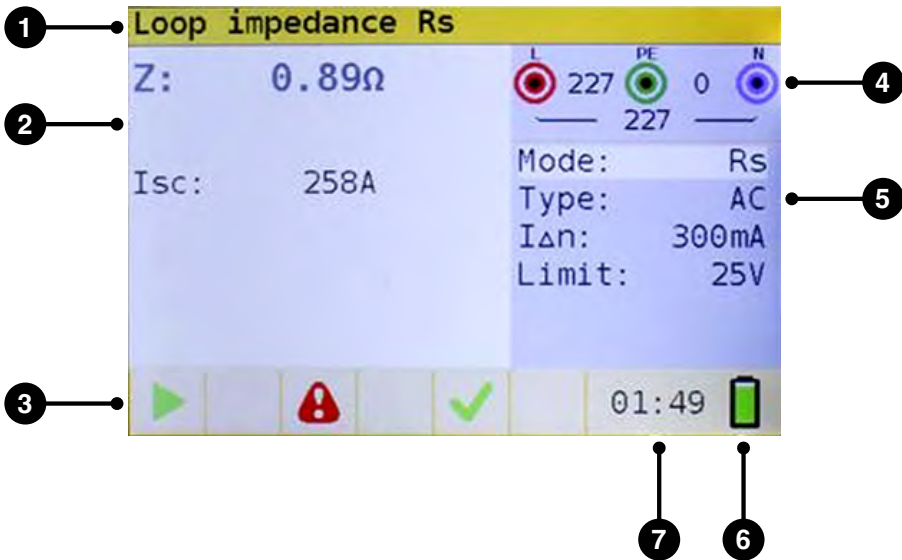
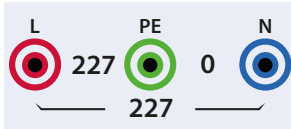

Figure 4.1: Display outlook

Legend:

1. Main function line
2. Result field –
In this field the main result and sub-results are displayed
3. Status field –
PASS / FAIL / ABORT / START / WAIT / WARNING status' are displayed
4. Online voltage and output monitor –
Indicates which plugs should be used for measurement being performed, always shows the actual voltages
5. Options field
6. Battery status indication
7. Current time

4.2 The online voltage and output terminal monitor



Online voltages are displayed together with test terminal indication. All three test terminals are used for selected measurement.

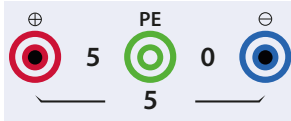

Online voltages are displayed together with test terminal indication. L and N test terminals are used for selected measurement.

4.3 Message field – battery status



Battery power indication.



Low battery indication. Battery pack is too weak to guarantee correct results. Replace or recharge the batteries.



Recharging is shown by a red LED near the supply socket.

4.4 Status field - measurement warnings / results symbols



Symbol	Meaning	Active in function:											
		Voltage rotation	R low	Continuity	R isolation	Line	Loop	Loop RCD	RCD time	RCD current	RCD auto	RCD Uc	Earth resistance
	Dangerous voltage	X	X	X	X	X	X	X	X	X	X	X	X
Zero	Test leads are zeroing		X	X									
	Measurement cannot be started		X	X	X								
	Dangerous voltage on PE	X	X	X	X	X	X	X	X	X	X	X	X
	Result is not ok		X	X	X	X	X	X	X	X	X	X	X
	Result is ok		X	X	X	X	X	X	X	X	X	X	X
	RCD open or tripped								X	X	X	X	
	RCD closed								X	X	X	X	
	Measurement can be started		X	X	X	X	X	X	X	X	X	X	X
	Temperature too high					X	X	X	X	X	X	X	
	Swap test leads	X	X	X	X	X	X	X	X	X	X	X	X
	Wait				X								
	Noise on signal					X	X	X	X	X	X	X	
	Check fuses		X	X	X								X

Figure 4.4 List of status symbols

4.5 Sound warnings

Short high sound	Button press
Continuous sound	During continuity test when result is $<35\Omega$
Increasing sound	Attention, dangerous voltage applied
Short sound	Power off, end of measurement
Decreasing sound	Warnings (temperature, voltage at input, start not possible)
Periodic sound	 Warning! Phase voltage on the PE terminal. Stop all measurements immediately and eliminate the fault before proceeding with any activity!

4.6 Performing measurements





4.6.1 Measurement function / sub-function

The following measurements can be selected with the function selector switch:

- Voltage / rotation / frequency measurement
- Earth resistance
- R Low
- R Insulation
- Line impedance
- Loop (Loop RCD) impedance
- RCD
- EVSE measurement (ET6300 & ET6500 only)



The function/sub-function name is highlighted on the display by default.

4.6.2 Selecting measurement function/ sub-function

Using navigation keys   select the parameter/limit value you want to edit. By using keys   the value for the selected parameter can be set.

Once the measurement parameters are set, the settings are retained until new changes are made.

4.6.3 Performing tests

When  symbol is displayed test can be started by pressing the “TEST” button. After completion of the test its result value and status will be displayed. In case of PASSED measurement, result value will be displayed in black along with the  status symbol. In case of NOT PASSED measurement, the result value will be marked in red along with the  symbol.

4.7 Setup menu

To enter the Setup menu, press the SETUP key. In the Setup menu, the following actions can be taken:

- **Isc factor:**
 - Set prospective short/fault current scaling factor
- **Date/Time:**
 - Set internal date and time
 - Calibration date (optional)
- **RCD standard:**
 - Select national standard for RCD testing, e.g BS EN 61008 or BS EN 7671
- **ELV:**
 - Select voltage for ELV warning
- **Power off time:**
 - Select time when device should switch off if not used
- **Cont timeout:**
 - Select time-out when measurement should stop automatically
- **ISO timeout:**
 - Select time-out when measurement should stop automatically
- **Supply system:**
 - Select supply network/system, e.g. TN or IT
- **Device info:**
 - Shows info about device, e.g. Firmware version
- **Buzzer:**
 - Set the options, when the buzzer should be active
- **Backlight:**
 - Set the level of the TFT display backlight

4.8 Help screen

The Help screens contain diagrams that show the correct use of the device.

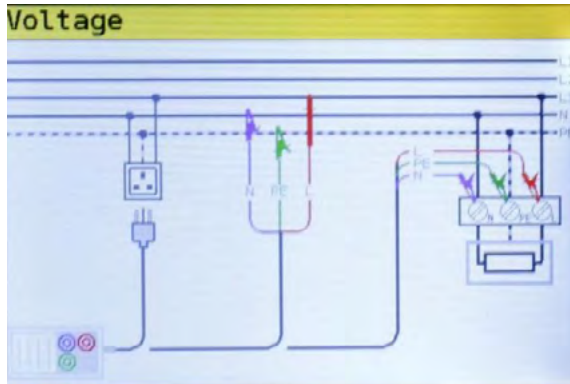

Figure 4.8: Example of a help screen

Press the HLP key to enter the help screen

Press the HLP key or the Exit / Back / Return key to exit the help screen

Press the Left and Right keys to switch to previous / next help screen

5. MEASUREMENTS

5.1 Insulation resistance

The Insulation resistance measurement is performed in order to ensure safety against electric shock. Using this measurement, the following items can be determined:

- Insulation resistance between installation conductors
- Insulation resistance of non-conductive rooms (walls and floors)
- Insulation resistance of ground cables
- Resistance of semi-conductive (antistatic) floors

How to perform an insulation resistance measurement

- Step 1** Select Insulation function with the function selector switch.
The following menu is displayed:

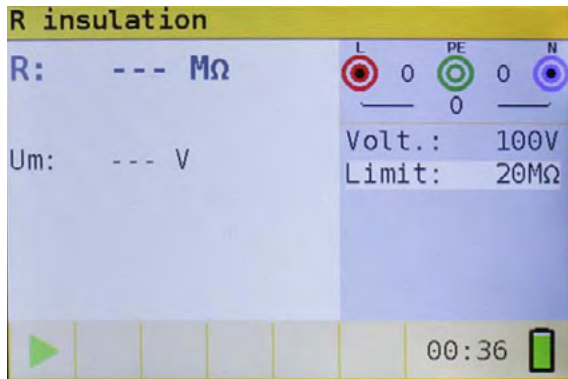

Figure 5.1: Insulation resistance measurement menu

- Step 2** Set the following measuring parameter and limit values:
- Volt: Nominal test voltage
 - Limit: Low limit resistance value

- Step 3** Ensure that no voltages are present on the item for testing. Connect the test leads to the ET6000 series instrument. Connect the test cables to the item under test. (see figure 5.2) to perform insulation resistance measurement.

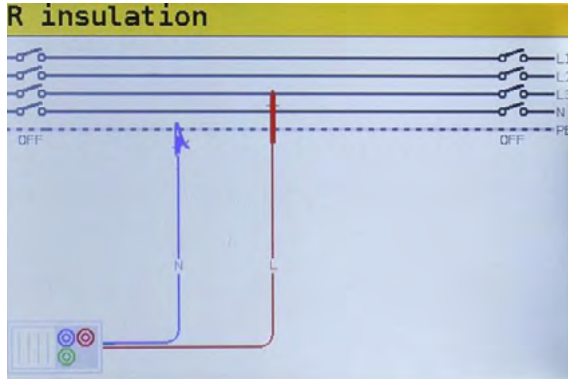

Figure 5.2: Connection of universal test cable

- Step 4** Check the displayed warnings and online voltage/terminal monitor before starting the measurement. If ► is displayed, press the **TEST** key. After the test is done, measured results are displayed, together with the ✓ or ✗ indication (if applicable).

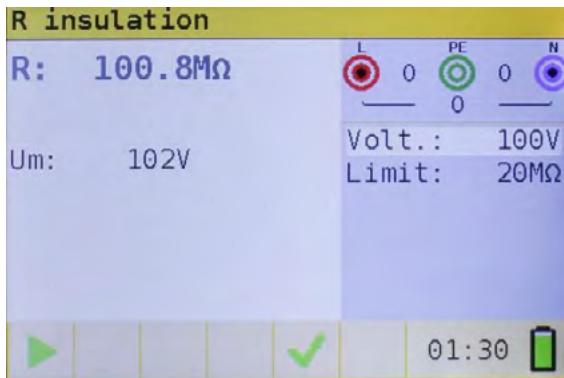

Figure 5.3: Example of insulation resistance measurement results

Displayed results:

- R** Insulation resistance
Um Actual voltage applied to item under test

Warnings:

- Insulation resistance measurement should only be performed on de-energized circuits.
- When measuring the insulation resistance between installation conductors, all loads must be disconnected, and all switches closed.
- Do not touch the test circuit during the measurement or before it is fully discharged to avoid risk of electric shock.
- In order to prevent damaging the test instrument, do not connect test terminals to an external voltage higher than 550V (AC or DC).

5.2 Continuity

Two continuity sub-functions are available:

- R Low, ca. 240mA continuity test with automatic polarity reversal.
- Low current (ca. 4mA) continuous continuity test (ET6300 & ET6500), useful when testing inductive systems.

5.2.1 R low test

This function is used to test the resistance between two different points of the installation to ensure that a conductive path exists between them. The test ensures that all protective conductors, earth conductors or bonding conductors are correctly connected, terminated and have the correct resistive value.

The measurement of the R Low resistance is performed with a test current of more than 200mA at 2Ω. An automatic polarity reversal of the test voltage and the test current is performed during the test. This test checks for any components (e.g. diodes, transistors, SCRs) that may have a rectifying effect on the circuit which could cause problems when a voltage is applied.

This measurement completely complies with BS EN 61557- 4.

How to perform a R Low resistance measurement

Step 1 Select the Continuity function with the function selector switch and select the R Low mode with the ▲▼ and ◀▶ navigation keys. The following menu will be displayed:

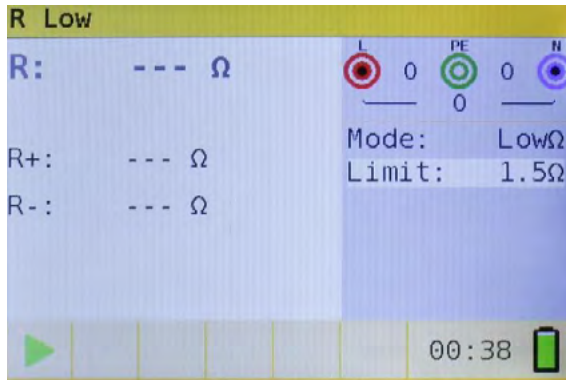

Figure 5.4: R Low resistance measurement menu

Step 2 Set the **following** limit value:

- Limit: limit resistance value using the ▲▼ and ◀▶ navigation keys.

Step 3 Connect test cable to the ET6000 series instrument. Before performing an R Low resistance measurement, compensate for the test leads resistance as follows:

1. Short test leads first as shown in figure 5.5.

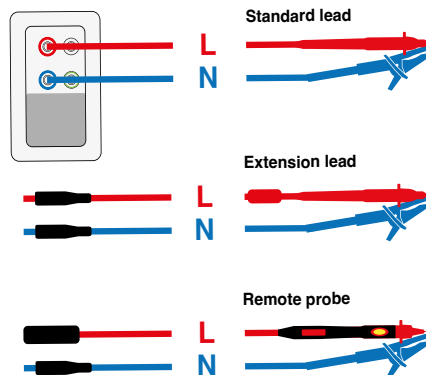

Figure 5.5: Shorted test leads

2. Press the **Zero / Null** key. After performing test leads compensation the compensated test leads indicator **COMP** will be displayed in the status line.
3. In order to remove any test lead resistance compensation, just press the **Zero / Null** key again. After removing any test lead compensation, the compensation indicator will disappear from the status line.

- Step 4** Ensure that the item / circuit for testing is disconnected from any voltage source and that it has been fully discharged. Connect the test cables to the item under test. Follow the connection diagrams shown in figures 5.6 and 5.7 to perform a R Low resistance measurement.

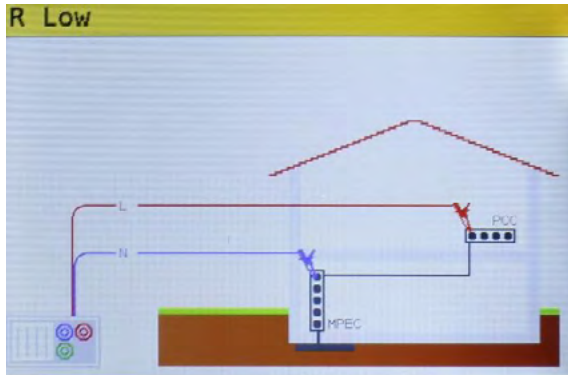

Figure 5.6: Connection of universal test cable



- Step 5** Check for any warnings and the online voltage/terminal monitor on the display before starting the measurement. If everything is ok and the  is shown, press the TEST key.
- After performing the measurement, the results appear on the display together with the  or  indication (if applicable).



Figure 5.7: Examples of R Low resistance measurement results

Displayed results:

- R** Main Low Ω resistance result (average of R+ and R- results)
- R+** Low Ω resistance sub-result with positive voltage at L terminal
- R-** Low Ω resistance sub-result with positive voltage at N terminal

⚠ Warnings:

- Low-value resistance measurements should only be performed on de-energized circuits.
- Parallel impedances or transient currents may influence test results.

Note: If the voltage between test terminals is higher than 10V the R Low measurement will not be performed

5.2.2 Continuity test

Continuous low-value resistance measurements can be performed without polarity reversal of the test voltages and a lower test current (a few mA). In general, the function serves as an ordinary Ω -meter with low test current. The function can also be used to test inductive components such as motors and coiled cables.

How to perform low current continuity measurement

Step 1 Select the Continuity function with the function selector switch and select the **Cont** mode with the \blacktriangle and \blacktriangleright navigation keys. The following menu will be displayed

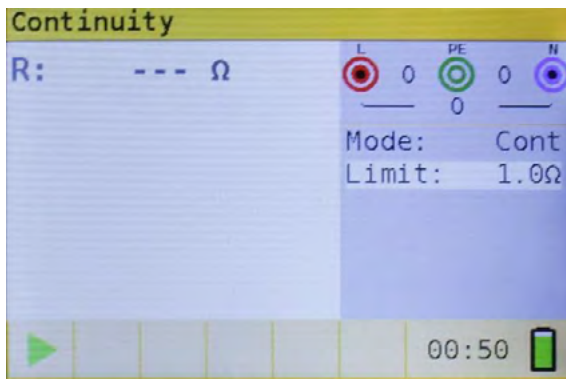

Figure 5.8: Continuity measurement menu

Step 2 Set the following limit value:
Limit: limit resistance value using the \blacktriangle and \blacktriangleright navigation keys.

- Step 3** Connect test cable to the instrument and the circuit under test. Follow the connection diagram shown in figures 5.9 and 5.10 to perform the Continuity measurement.

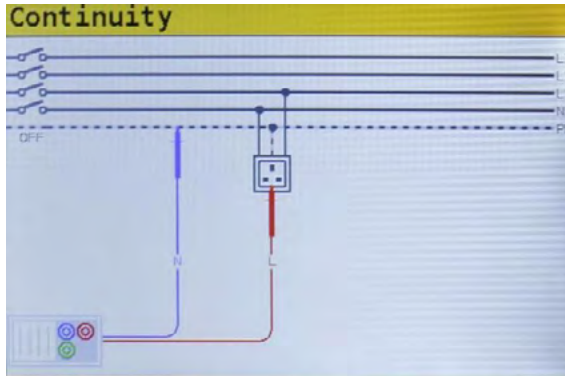

Figure 5.9: Connection of universal test cable

- Step 4** Check the warnings and online voltage/terminal monitor on the display before starting the measurement. If everything is OK and the ► is shown, press the **TEST** key to start the measurement. The actual measuring result with the ✓ or ✗ indication (if applicable) will be displayed during the measurement. As this is a continuous test, the function will require stopping. To stop the measurement at any time press the **TEST** key again. The last measured result will be displayed together with the ✓ or ✗ indication (if applicable).

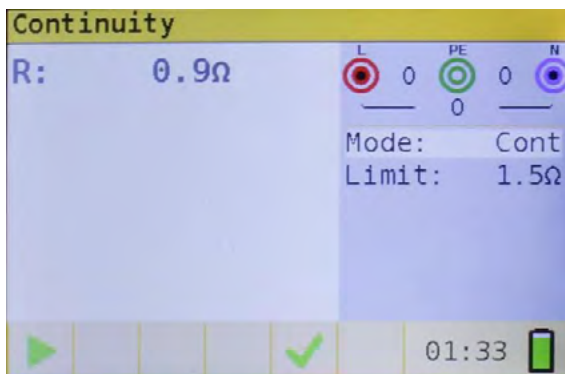

Figure 5.10: Example of Low current continuity measurement result

Displayed result:

- R** Low current continuity resistance result.
- I** Current used in the measurement

 **Warning:**

- Low current continuity measurement should only be performed on de-energized circuits

Notes:

- If a voltage of higher than 10V exists between test terminals, the continuity measurement will not be performed.
Before performing a continuity measurement, compensate for the test lead resistance (if necessary).

5.3 Testing RCDs

When testing RCDs, the following sub-functions can be performed:

- Contact voltage measurement
- Trip-out time measurement
- Trip-out current measurement
- RCD autotest

In general, the following parameters and limits can be set when testing RCDs:

- Limit contact voltage
- Nominal differential RCD trip-out current
- Multiplier of nominal differential RCD trip-out current
- RCD type
- Test current starting polarity

For possible parameters that could be set check the specification tables at the end of this manual.

5.3.1 Limit contact voltage

Safety contact voltage is limited to 50V AC for standard domestic areas. In special environments (hospitals, wet places, etc.) contact voltages should be below 25V AC. Limit contact voltage can be set in contact voltage U_c function only.

5.3.2 Nominal differential trip-out current

Nominal differential current is the rated trip-out current of an RCD. The following RCD current ratings can be set: 6mA*, 10mA, 30mA, 100mA, 300 mA, 500mA, 650mA* and 1000mA*. (*ET6300 & ET6500 only)

5.3.3 Multiplier of nominal residual current

Selected nominal differential current can be multiplied by $\frac{1}{2}$, 1, 2 or 5.

5.3.4 RCD type and test current starting polarity

The ET6000 series instruments enable testing of general (non-delayed) and selective (time- delayed) RCDs. The types of RCD the instrument is suitable for testing include:

- Alternating residual current (AC type)
- Pulsating DC residual current (A type)
- Pure or nearly pure DC residual current (B type) (dependent on model)
- Special RCDs for EVSE applications
- Test current starting polarity can be started with the positive half-wave at 0° or with the negative half-wave at 180°

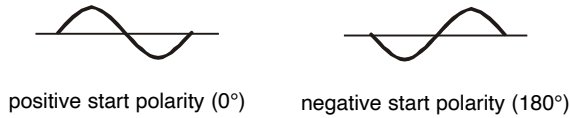

Figure 5.11: Test current started with the positive or negative half-wave

5.3.5 Testing selective (time-delayed) RCDs

Selective RCDs demonstrate delayed response characteristics. Trip-out performance is influenced due to pre-loading during measurement of contact voltage. In order to eliminate the pre-loading a time delay of 30s is inserted before performing the trip-out test.

5.3.6 Contact voltage

Leakage current flowing to the PE terminal causes a voltage drop across earth resistance, which is called contact voltage (U_c). This voltage is present on all accessible parts connected to the PE terminal and should be lower than the safety limit voltage.

The parameter contact voltage is measured without tripping-out the RCD. R_L is a fault loop resistance and is calculated as follows:

$$R_L = \frac{U_c}{I_{\Delta N}}$$

Displayed contact voltage relates to the rated nominal differential current of the RCD and is multiplied by a safety factor. See the table 5.1 for detailed contact voltage calculation.





RCD type	Contact voltage U_c
 G	$U_c \propto 1.05 \times I_{\Delta N}$
 S	$U_c \propto 1.05 \times 2 \times I_{\Delta N}$
 G	$U_c \propto 1.05 \times \sqrt{2} \times I_{\Delta N}$
 S	$U_c \propto 1.05 \times 2 \times \sqrt{2} \times I_{\Delta N}$

Table 5.1: Relationship between U_c and $I_{\Delta N}$

How to perform contact voltage measurement

- Step 1** Select the RCD function with the function selector switch and select the Uc mode with the ▲▼ and ◀▶ navigation keys. The following menu will be displayed:

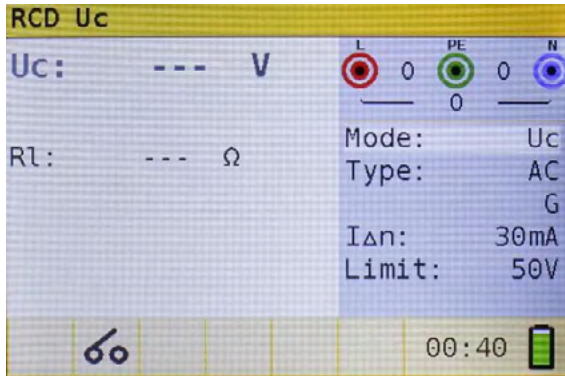

Figure 5.12: Contact voltage measurement menu

- Step 2** Set the following measuring parameters and limit values:

2. $I_{\Delta N}$: Nominal residual current
3. Type: RCD type
4. Limit: Limit contact voltage

- Step 3** Connect the test leads to the instrument and follow the connection diagram shown in figure 5.13 to perform contact voltage measurement.

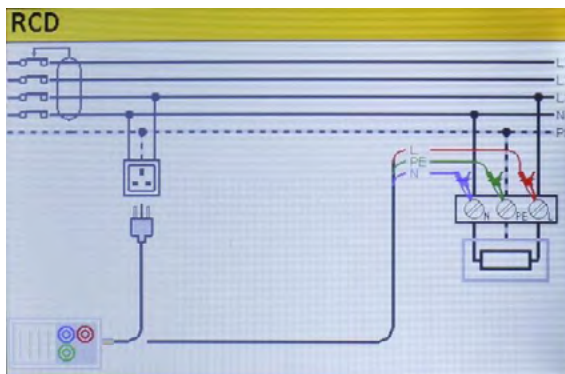

Figure 5.13: Connection of plug test cable or universal test cable

- Step 4** Check for any warnings and check the online voltage/terminal monitor on the display before starting the measurement. If everything is ok and the ► is shown, press the **TEST** key. After performing the measurement, the results appear on the display together with the ✓ or ✗ indication.

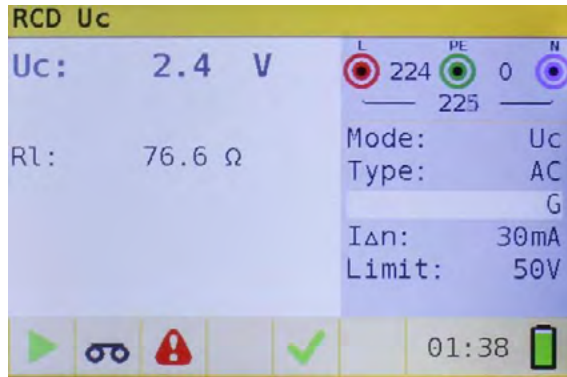

Figure 5.14: Example of contact voltage measurement results

Displayed results:

Uc Contact voltage.

Rl Fault loop resistance.

Limit Limit earth fault loop resistance value according to BS EN 7671

Notes:

- Parameters set in this function are also kept for all other RCD functions.
- The measurement of contact voltage does not normally trip an RCD. However, the trip limit may be exceeded as a result of leakage currents flowing through the PE protective conductor or a capacitive connection between the L and PE conductor.
- RCD non-trip sub-function (function selected to LOOP RCD option) takes longer to complete but offers much better accuracy of a fault loop resistance result (in comparison with the RL sub-result in Contact voltage function).

5.3.7 Trip-out time

Trip-out time measurement is used to verify the effectiveness of an RCD. This is achieved by a test simulating an appropriate fault condition. Trip-out times vary between standards and are listed below.

Trip-out times according to BS EN 61008 / BS EN 61009:

	$\frac{1}{2} x I_{\Delta N}$	$I_{\Delta N}$	$2xI_{\Delta N}$	$5xI_{\Delta N}$
General (non-delayed) RCDs	$t_{\Delta} > 300\text{ms}$	$t_{\Delta} > 300\text{ms}$	$t_{\Delta} > 150\text{ms}$	$t_{\Delta} > 40\text{ms}$
Selective (time-delayed) RCDs	$t_{\Delta} > 500\text{ms}$	$130\text{ms} < t_{\Delta} < 500\text{ms}$	$60\text{ms} < t_{\Delta} < 200\text{ms}$	$50\text{ms} < t_{\Delta} < 150\text{ms}$

Trip-out times according to BS 7671:

	$\frac{1}{2} x I_{\Delta N}$	$I_{\Delta N}$	$2xI_{\Delta N}$	$5xI_{\Delta N}$
General (non-delayed) RCDs	$t_{\Delta} > 1999\text{ms}$	$t_{\Delta} > 300\text{ms}$	$t_{\Delta} > 150\text{ms}$	$t_{\Delta} > 40\text{ms}$
Selective (time-delayed) RCDs	$t_{\Delta} > 1999\text{ms}$	$130\text{ms} < t_{\Delta} < 500\text{ms}$	$60\text{ms} < t_{\Delta} < 200\text{ms}$	$50\text{ms} < t_{\Delta} < 150\text{ms}$

*) Test current of $\frac{1}{2}xI_{\Delta N}$ cannot cause trip-out of the RCDs.

Trip-out times according to IEC 62955:

	$I_{\Delta N\text{dc}}$	$10xI_{\Delta N\text{dc}}$	$33xI_{\Delta N\text{dc}}$	
6 mADC RCDs	$t_{\Delta} > 10.00\text{ms}$	$t_{\Delta} > 300\text{ms}$	$t_{\Delta} > 100\text{ms}$	
	$I_{\Delta N}$	$2xI_{\Delta N}$	$5xI_{\Delta N}$	$167xI_{\Delta N}$
30 mAAC RCDs	no trip	$t_{\Delta} < 300\text{ms}$	$t_{\Delta} < 80\text{ms}$	$t_{\Delta} < 80\text{ms}$

How to perform trip-out time measurement

- Step 1** Select the RCD function with the function selector switch and select the **Time** mode with the \blacktriangle \blacktriangledown and \blacktriangleleft \blacktriangleright navigation keys. The following menu will be displayed:

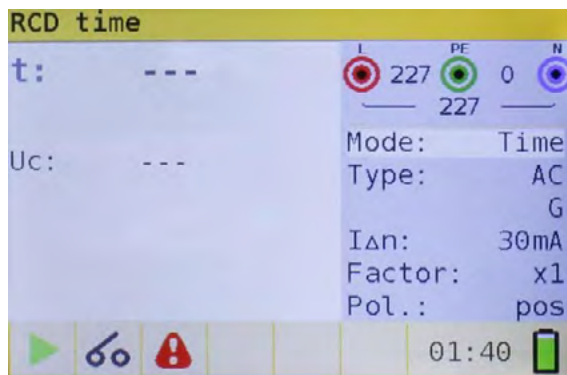





Figure 5.15: Trip-out time measurement menu

Step 2 Set the following measuring parameters:

1. **$I_{\Delta N}$** : Nominal differential trip-out current
2. **Factor**: Nominal differential trip-out current multiplier
3. **Type**: RCD type
4. **Pol.**: Test current starting polarity

Step 3 Connect the leads to the instrument and follow the connection diagram shown in figure 5.15 (see section 5.3.6 contact voltage) to perform trip-out time measurement.

Step 4 Check for any warnings and check the online voltage/terminal monitor on the display before starting the measurement. If everything is ok and the  is shown, press the **TEST** key. After performing the measurement, the results appear on the display together with the  or  indication.

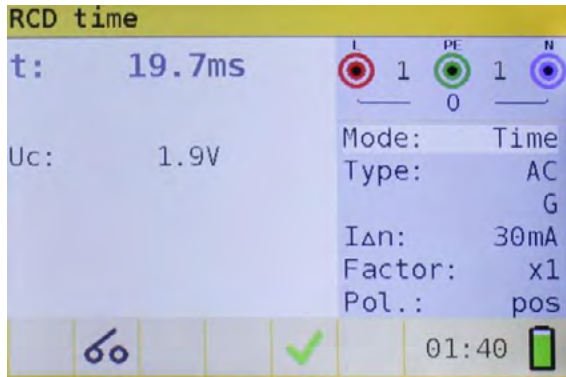

Figure 5.16: Example of trip-out time measurement results

Displayed results:

t Trip-out time

U_c Contact voltage

Notes:

- Parameters set in this function are also transferred onto all other RCD functions.
- RCD trip-out time measurement will be performed only if the contact voltage at nominal differential current is lower than the limit set in the contact voltage setting.
- The measurement of the contact voltage in pre-test does not normally trip an RCD. However, the trip limit may be exceeded as a result of leakage current flowing through the PE protective conductor or a capacitive connection between L and PE conductors.

5.3.8 Trip-out current

This test is used to determine the minimum current required to trip the RCD. After the measurement has been started, the test current generated by the instrument is continuously increased, starting at $0.2 \times I_{\Delta N}$ to $1.1 \times I_{\Delta N}$ (to $1.5 \times I_{\Delta N}$ / $2.2 \times I_{\Delta N}$ ($I_{\Delta N} = 10$ mA) for pulsating DC residual currents), until the RCD trips.

How to perform trip-out current measurement

Step 1 Select the RCD function with the function selector switch and select the **Ramp** mode with the \blacktriangle and \blacktriangleleft navigation keys. The following menu will be displayed:

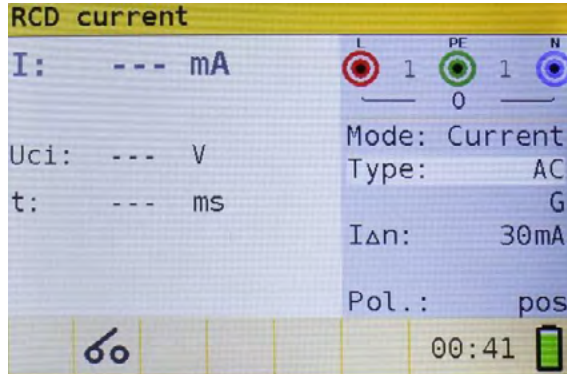

Figure 5.17: Trip-out current measurement menu

Step 2 By using cursor keys the following parameters can be set in this measurement:

1. **$I_{\Delta N}$** : Nominal residual current
2. **Type**: RCD type
3. **Pol.**: Test current starting polarity

Step 3 Connect the test leads to the instrument and follow the connection diagram shown in figure 5.15 (see section 5.3.6 Contact voltage) to perform trip-out current measurements.

Step 4 Check for any warnings and check the online voltage/terminal monitor on the display before starting the measurement. If everything is ok and the \blacktriangleright is shown, press the **TEST** key. After performing the measurement, the results appear on the display together with the \checkmark or \times indication.

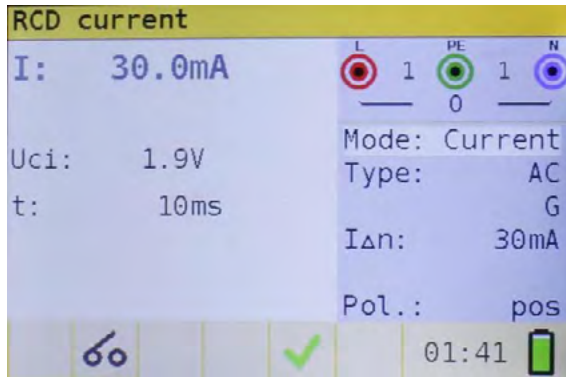

Figure 5.18: Example of trip-out current measurement result

Displayed results:

I	Trip-out current
Uci	Contact voltage
t	Trip-out time

Notes:

- Parameters set in this function are also kept for other RCD functions.
- RCD trip-out current measurement will be performed only if the contact voltage at nominal differential current is lower than set limit contact voltage.
- The measurement of contact voltage in the pre-test does not normally trip an RCD. However, the trip limit may be exceeded as a result of leakage current flowing through the PE protective conductor or a capacitive connection between L and PE conductors.

5.3.9 Autotest

The purpose of the autotest function is to perform a complete RCD testing and measurement of most important associated parameters (contact voltage, fault loop resistance and trip-out time at different fault currents) with one press of a button. If a faulty parameter is noticed during the autotest, the test will stop to highlight the need for further investigation.

Notes:

- The measurement of contact voltage in the pre-test does not normally trip an RCD. However, the trip limit may be exceeded as a result of leakage current flowing through the PE protective conductor or a capacitive connection between L and PE conductors.
- The autotest sequence stops when the trip-out time is out of the allowed time period.

5.3.9.1 How to perform RCD autotest

Step 1 Select the **RCD** function with the function selector switch and select the **Auto** mode with the ▲▼ and ◀▶ navigation keys. The following menu will be displayed:

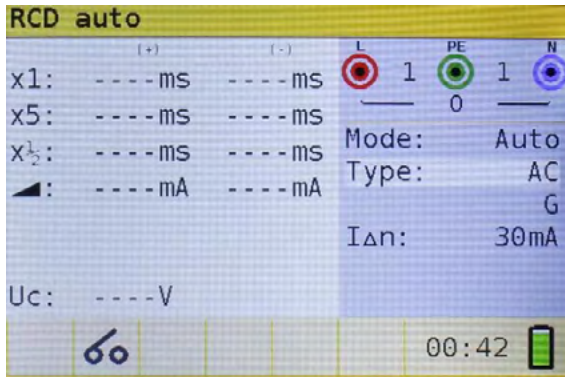

Figure 5.19: RCD autotest menu

Step 2 Set the following measuring parameters:

1. **$I_{\Delta N}$** : Nominal differential trip-out current
2. **Type**: RCD type

Step 3 Connect the test leads to the instrument and follow the connection diagram shown in figure 5.15 (also see section 5.3.6 Contact voltage) to perform the RCD autotest.

Step 4 Check for any warnings and check the online voltage/terminal monitor on the display before starting the measurement. If everything is ok and the ► is shown, press the TEST key. The autotest sequence will then start to run as follows:

1. Trip-out time measurement with the following measurement parameters:
 - Test current of $I_{\Delta N}$
 - Test current started with the positive half-wave at 0°

Measurement normally trips an RCD within the allowed time period. The following menu is displayed:



Figure 5.20: Step 4.1 RCD autotest results

After re-activating the RCD, the autotest sequence automatically proceeds with step 2.

2. Trip-out time measurement with the following measurement parameters:

- Test current of $I_{\Delta N}$
- Test current started with the negative half-wave at 180°

Measurement normally trips an RCD. The following menu is displayed:

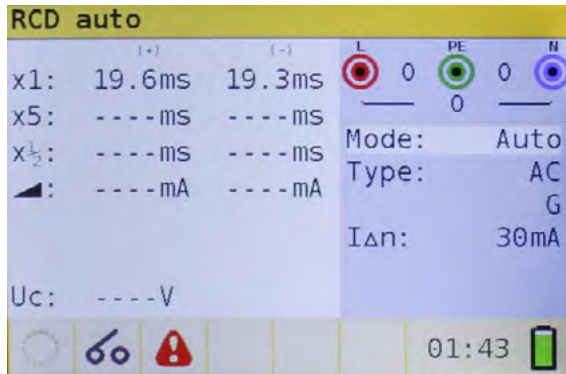

Figure 5.21: Step 4.2 RCD autotest results

After re-activating the RCD, the autotest sequence automatically proceeds with step 4.3.

3. Trip-out time measurement with the following measurement parameters:

- Test current of $5xI_{\Delta N}$,
- Test current started with the positive half-wave at 0° .

Trip-out time measurement with the following measurement parameters:

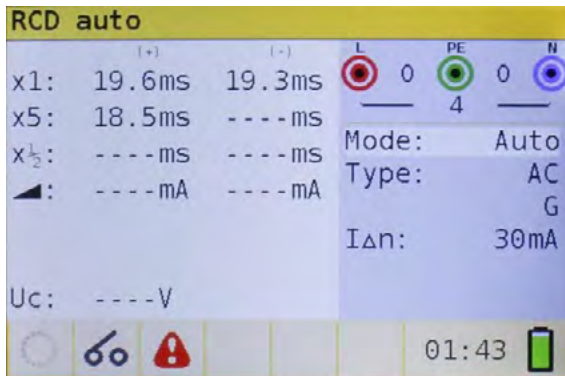

Figure 5.22: Step 4.3 RCD autotest results

After re-activating the RCD the autotest sequence automatically proceeds with step 4.4.

4. Trip-out time measurement with the following measurement parameters:

- Test current of $5xI_{\Delta N}$,
- Test current started with the negative half-wave at 180° .

Measurement normally trips an RCD within the allowed time period. The following menu is displayed:

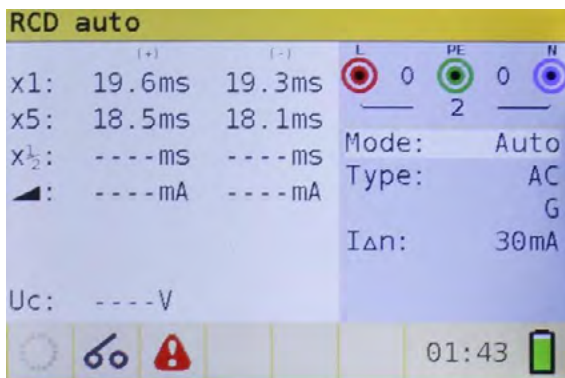

Figure 5.23: Step 4.4 RCD autotest results

After re-activating the RCD the autotest sequence automatically proceeds with step 4.5.

5. Trip-out time measurement with the following measurement parameters:

- Test current of $\frac{1}{2}I_{\Delta N}$,
- Test current started with the positive half-wave at 0° .

Measurement does not normally trip an RCD. The following menu is displayed:

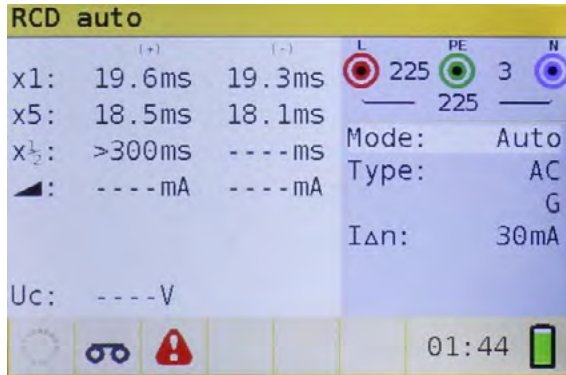

Figure 5.24: Step 4.5 RCD autotest results

After performing step 5 the RCD autotest sequence automatically proceeds with step 4.6.

6. Trip-out time measurement with the following measurement parameters:

- Test current of $\frac{1}{2}I_{\Delta N}$
- Test current started with the negative half-wave at 180°

Measurement does not normally trip an RCD. The following menu is displayed:

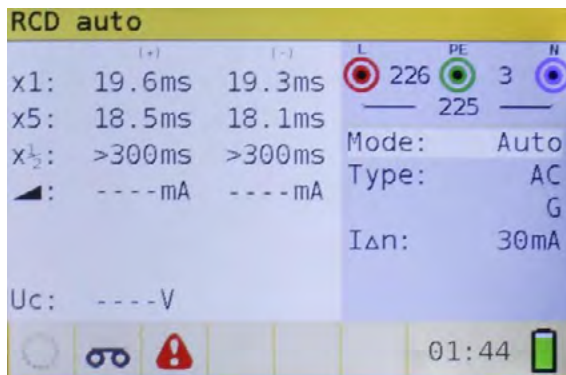

Figure 5.25: Step 4.6 RCD autotest results

7. Ramp test measurement with the following measurement parameters:

- Test current started with the positive half-wave at 0° .

This measurement determine the minimum current required to trip the RCD. After the measurement has been started, the test current generated by the instrument is continuously increased, until the RCD trips. The following menu is displayed:

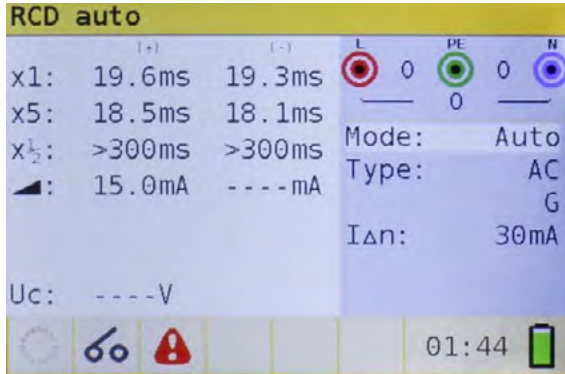

Figure 5.26: Step 4.7 RCD autotest results

8. Ramp test measurement with the following measurement parameters:

- Test current started with the negative half-wave at 180°

This measurement determine the minimum current required to trip the RCD. After the measurement has been started, the test current generated by the instrument is continuously increased, until the RCD trips. The following menu is displayed:

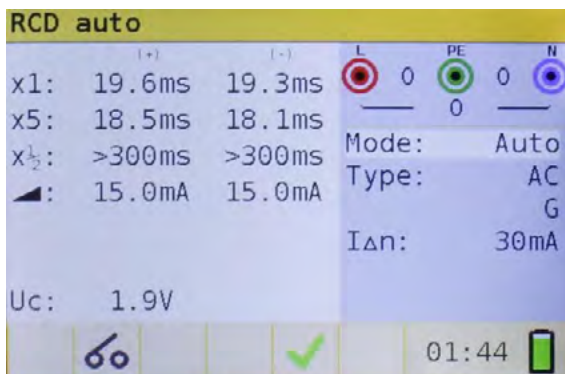

Figure 5.27: Step 4.8 RCD autotest results

Displayed results:

x1 (left)	Step 1 trip-out time result, $t_3 (I_{\Delta N}, 0^\circ)$
x1 (right)	Step 2 trip-out time result, $t_4 (I_{\Delta N}, 180^\circ)$
x5 (left)	Step 3 trip-out time result, $t_5 (5 \times I_{\Delta N}, 0^\circ)$
x5 (right)	Step 4 trip-out time result, $t_6 (5 \times I_{\Delta N}, 180^\circ)$
x½ (left)	Step 5 trip-out time result, $t_1 (\frac{1}{2} \times I_{\Delta N}, 0^\circ)$
x½ (right)	Step 6 trip-out time result, $t_2 (\frac{1}{2} \times I_{\Delta N}, 180^\circ)$
IΔ (+)	Step 7 trip-out current ((+) positive polarity)
IΔ (-)	Step 8 trip-out current ((-) negative polarity)
Uc	Contact voltage for rated $I_{\Delta N}$

Note:

- The **x1** Auto tests will be automatically skipped for RCD type B with rated residual currents of $I_{\Delta N} = 1000\text{mA}$
- The **x5** Auto tests will be automatically skipped in the following cases:
 - RCD type AC with rated residual currents of $I_{\Delta N} = 1000\text{mA}$
 - RCD type A and B with rated residual currents of $I_{\Delta N} \geq 300\text{mA}$
- In these cases, the auto test result passes if the t_1 to t_4 results pass, and t_5 and t_6 are omitted

WARNINGS

- Leakage currents in the circuit following the residual current device (RCD) may influence the measurements.
- Special conditions in residual current devices (RCD) of a particular design, for example of type S (selective and resistant to impulse currents) shall be taken into consideration.
- Equipment in the circuit following the residual current device (RCD) may cause a considerable extension of the operating time. Examples of such equipment might be connected capacitors or running motors.

5.4 Fault loop impedance and prospective fault current

The loop impedance function has three sub-functions available:

LOOP IMPEDANCE sub-function performs a fast fault loop impedance measurement on supply systems which do not contain RCD protection.

LOOP IMPEDANCE RCD sub-function performs fault loop impedance measurement on supply systems which are protected by RCDs.

LOOP IMPEDANCE Rs sub-function with configurable RCD-value performs fault loop impedance measurement on supply systems which are protected by RCDs.

5.4.1 Fault loop impedance

The fault loop impedance measures the impedance of the fault loop in the event that a short-circuit to an exposed conductive part occurs (i.e. a conductive connection occurs between the phase conductor and protective earth conductor). In order to measure loop impedance, the instrument uses a high-test current.

Prospective fault current (IPFC) is calculated on the basis of the measured resistance as follows:

$$I_{PFC} = \frac{U_N \times \text{scaling factor}}{Z_{L-PE}}$$

Where:

Nominal input voltage U_N	Voltage range
115V	$(93V \leq U_{L-PE} < 134V)$
230V	$(185V \leq U_{L-PE} \leq 266V)$

How to perform fault loop impedance measurement

- Step 1** Select the **LOOP** function with the function selector switch and select the **LOOP** mode with the **▲▼** and **◀▶** navigation keys. Then select desired Type (select various types or custom or off), **Time** and **Curr** option values with the **▲▼** and **◀▶** navigation keys. The following menu is displayed:

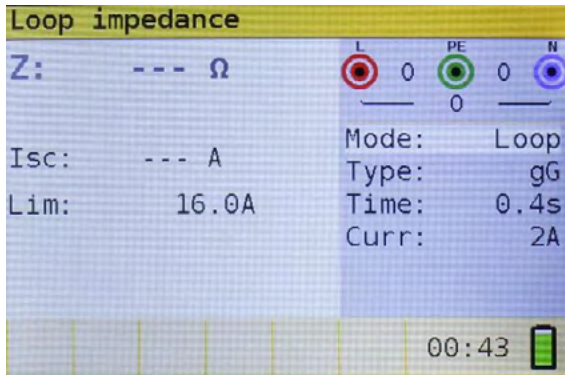

Figure 5.28: Loop impedance measurement menu

- Step 2** Connect the test leads to the instrument and follow the connection diagram shown in the figure 5.29 to perform fault loop impedance measurement.

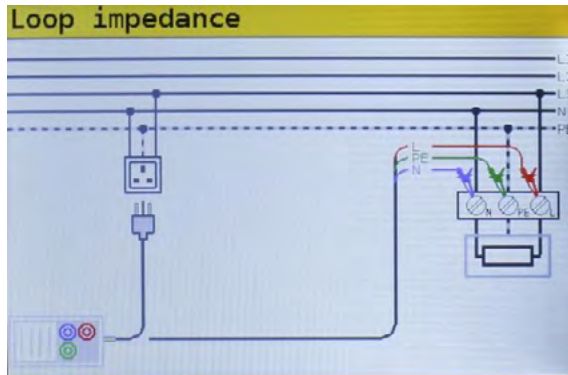



Figure 5.29: Connection of plug cable and universal test cable

- Step 3** Check for any warnings displayed on the screen and check the online voltage/terminal monitor before starting the measurement. If everything is ok and the  is shown, press the **TEST** key. After performing the measurement, the test results will appear on the display.

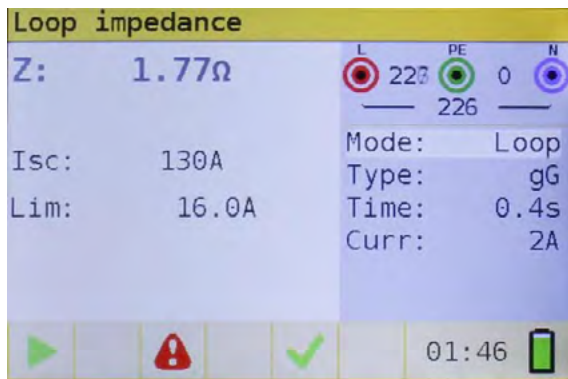

Figure 5.30: Example of loop impedance measurement results

Displayed results:

- Z** Fault loop impedance,
- ISC** Prospective fault current (displayed in amps),

Note:

- The specified accuracy of test parameters is valid only if mains voltage is stable during the measurement.
- The Fault loop impedance measurement trips RCD protected circuits.

5.4.2 The fault loop impedance test RCD (for RCD protected circuits)

The fault loop impedance is measured with a low test current to avoid tripping the RCD. This function can also be used for fault loop impedance measurement in system equipped with RCDs which have a rated trip-out current of 30mA and above.

Prospective fault current (IPFC) is calculated on basis of measured resistance as follows:

$$I_{PFC} = \frac{U_N \times \text{scaling factor}}{Z_{L-PE}}$$

Where:

Nominal input voltage U_N	Voltage range
115V	$(93V \leq U_{L-PE} < 134V)$
230V	$(185V \leq U_{L-PE} \leq 266V)$

How to perform a non-trip RCD measurement

- Step 1** Select the **LOOP** function with the function selector switch and select the **RCD** mode with the $\blacktriangle\blacktriangledown$ and $\blacktriangleleft\blacktriangleright$ navigation keys. Then select desired **Type** (select various types or custom or off), Time and Curr option values with the $\blacktriangle\blacktriangledown$ and $\blacktriangleleft\blacktriangleright$ navigation keys. The following menu is displayed:

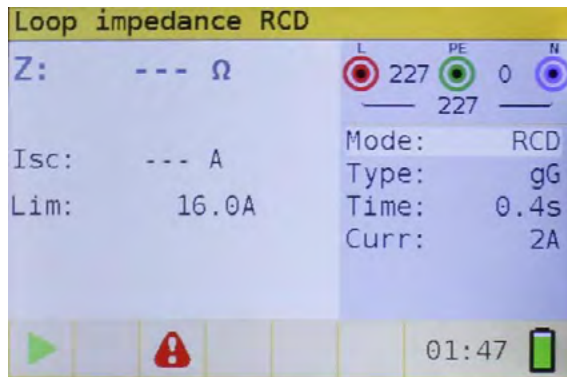

Figure 5.31: Trip-lock function menu

- Step 2** Connect the appropriate test leads to the instrument and follow the connection diagram shown in figure 5.13 to perform RCD non-trip measurement (see section 5.3.6 Contact voltage).
- Step 3** Check for warnings on the display and check the online voltage/terminal monitor before starting the measurement. If everything is ok and the \blacktriangleright is shown, press the **TEST** key. After performing the measurement, the results will appear on the display.

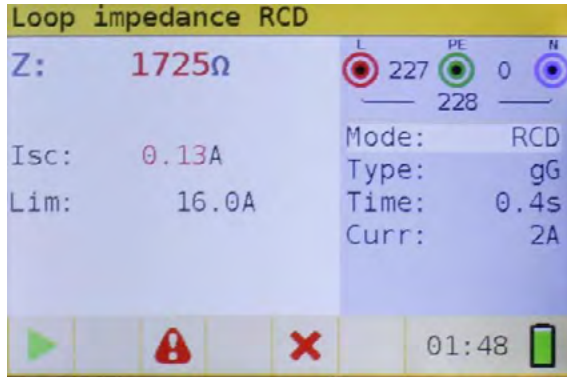

Figure 5.32: Example of fault loop impedance measurement results using RCD function

Displayed result:

- Z** Fault loop impedance,
- ISC** Prospective fault current (PFC)

Notes:

- The measurement of fault loop impedance using trip-lock function does not normally trip an RCD. However, if the trip limit may be exceeded as a result of leakage current flowing through the PE protective conductor or a capacitive connection between L and PE conductors.
- The specified accuracy of test parameter is valid only if mains voltage is stable during the measurement.

5.4.3 The fault loop impedance test Rs (for adjustable current)

The fault loop impedance is measured with a low test current to avoid tripping the RCD. It is possible to adjust the value of the RCD, while the test current depends on the chosen value. With this function it is possible to test each RCD-type with the maximum possible current without tripping the RCD.

Prospective fault current (IPFC) is calculated on basis of measured resistance as follows:

$$I_{PFC} = \frac{U_N \times \text{scaling factor}}{Z_{L-PE}}$$

Where:

Nominal input voltage U_N	Voltage range
115V	$(93V \leq U_{L-PE} < 134V)$
230V	$(185V \leq U_{L-PE} \leq 266V)$

How to perform Rs trip-lock measurement

- Step 1** Select the LOOP function with the function selector switch and select the Rs mode with the ▲▼ and ◀▶ navigation keys. Then select desired Type (select various types or custom or off), **current**, **Limit** and **scaling factor** option values with the ▲▼ and ◀▶ navigation keys. The following menu is displayed:

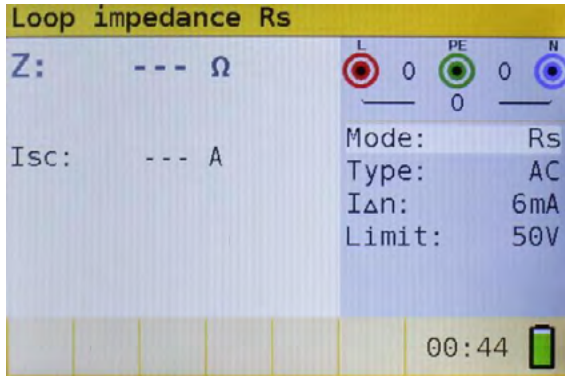

Figure 5.33: Loop impedance Rs function menu

- Step 2** Connect the appropriate test leads to the instrument and follow the connection diagram shown in figure 5.13 to perform RCD non-trip measurement (see section 5.3.6 Contact voltage).



Figure 5.34: Example of fault loop impedance measurement results using Rs function

Check for warnings on the display and check the online voltage/terminal monitor before starting the measurement. If everything is ok and the ► is shown, press the TEST key. After performing the measurement, the results will appear on the display.

Displayed result:

- Z** Fault loop impedance
ISC Prospective fault current

Notes:

- The measurement of fault loop impedance using trip-lock function does not normally trip an RCD. However, if the trip limit may be exceeded as a result of leakage current flowing through the PE protective conductor or a capacitive connection between L and PE conductors.
- The specified accuracy of test parameter is valid only if mains voltage is stable during the measurement.

5.5 Line impedance and prospective short-circuit current

The line impedance is a measurement of the impedance of the current loop when a short-circuit to the neutral conductor occurs (conductive connection between phase conductor and neutral conductor in single-phase system or between two phase conductors in three-phase system). A high test current is used to perform the line impedance measurement.

Prospective short circuit current is calculated as follows:

$$I_{PFC} = \frac{U_N \times \text{scaling factor}}{Z_{L-N(L)}}$$

Where:

Nominal input voltage U_N	Voltage range
115V	$(93V \leq U_{L-PE} < 134V)$
230V	$(185V \leq U_{L-PE} \leq 266V)$
400V	$(321V \leq U_{L-PE} \leq 485V)$

How to perform line impedance measurement

- Step 1** Select the **LINE IMPEDANCE** function with the function selector switch. Then select desired Type (select various types or custom or off), **Time** and **Curr** option values with the ▲▼ and ◀▶ navigation keys. The following menu is displayed:

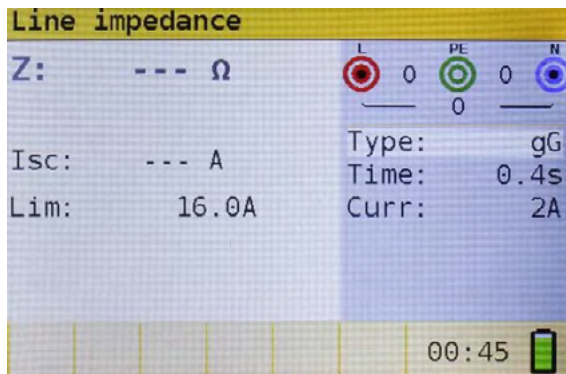

Figure 5.35: Line impedance measurement menu

- Step 2** Connect the appropriate test leads to the instrument and follow the connection diagram shown in figure 5.36 to perform phase-neutral or phase-phase line impedance measurement.

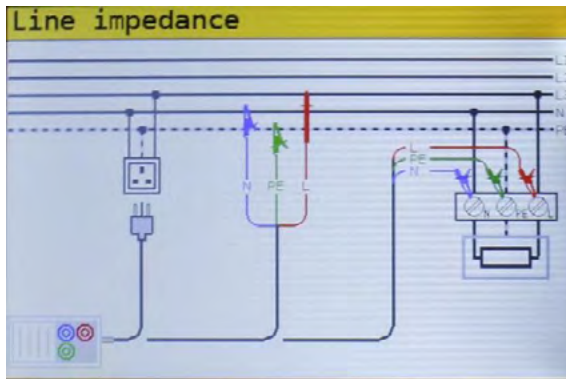



Figure 5.356: Line impedance measurement

- Step 3** Check for warnings displayed on the screen and check the online voltage/terminal monitor before starting the measurement. If everything is ok and the  is shown, press the **TEST** key. After performing the measurement, the results will appear on the display.

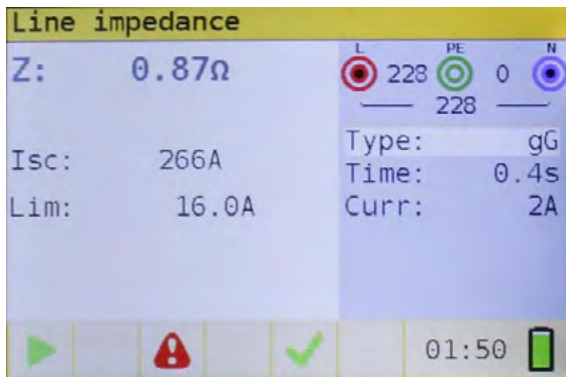

Figure 5.367: Example of line impedance measurement results

Displayed results:

- Z** Line impedance
ISC Prospective short-circuit current

Notes:

- The specified accuracy of the test parameter is valid only if mains voltage is stable during the measurement.

5.5.1 Voltage drop test (ET6500 Only)

The voltage drop function is a measurement of the line impedance (see section 5.5) and result is compared to a reference result which has been taken before on some other point of the installation (usually the entry point since this point has the lowest impedance). The voltage drop in %, the impedance and the prospective short circuit current are shown.

The voltage drop in % is calculated as follows:

$$I_{PFC} = \frac{U_N \times \text{scaling factor}}{Z_{L-N(L)}}$$

How to perform voltage drop measurement

- Step 1** Select the LINE IMPEDANCE function with the function selector switch and select Voltage drop with the ▲▼ and ◀▶ navigation keys. Then select desired Type (select various types or custom or off), **Time** and **Curr** option values with the ▲▼ and ◀▶ navigation keys. The following menu is displayed:

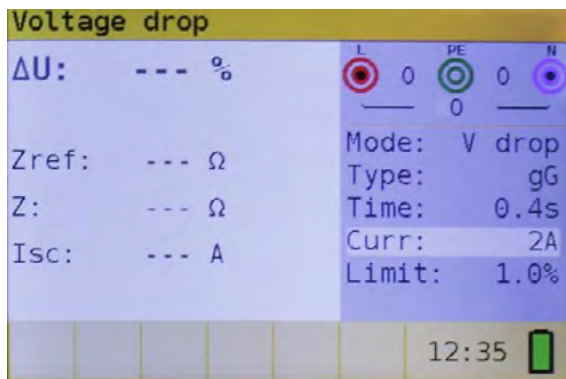

Figure 5.38: Voltage drop measurement menu

- Step 2** Connect the appropriate test leads from the reference point to the instrument and follow the connection diagram shown in figure 5.36 to perform phase-neutral or phase-phase line impedance measurement.
- Step 3** Press **Zero / Null** key and 'REF' will be shown in display. The device is then ready to take the measurement of the reference position in the installation. Check for warnings displayed on the screen and check the online voltage/terminal monitor before starting the measurement. If everything is ok and the ► is shown, press the **TEST** key. After performing the measurement, the result for Zref will appear on the display.
- Step 4** Connect the appropriate test leads from the tested point to the instrument and follow the connection diagram shown in figure 5.36 to perform phase-neutral or phase-phase line impedance measurement. Check for warnings displayed on the screen and check the online voltage/terminal monitor before starting the measurement. If everything is ok and the ► is shown, press the **TEST** key. After performing the measurement, the results will appear on the display.

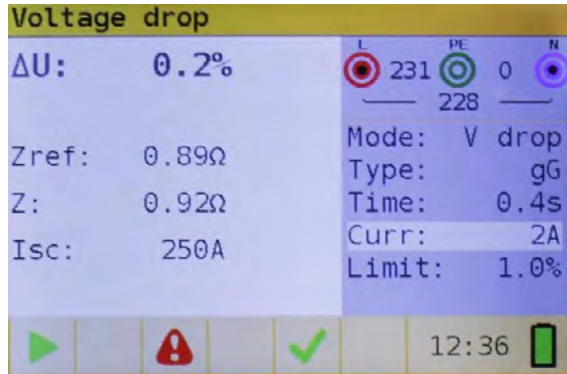

Figure 5.379: Example of voltage drop measurement results

Displayed results:

- ΔU** Voltage drop of the test point compared to the reference point
- Zref** Line impedance of the reference point
- Z** Line impedance of the test point
- Isc** Prospective short-circuit current of the test point

Notes:

- The specified accuracy of the test parameter is valid only if mains voltage is stable during the measurement.

5.6 Phase sequence testing

Some loads (ventilators, conveyors, motors, electro-mechanical machines, etc.) require a specific phase rotation and some may even be damaged if the rotation is reversed. It is advisable to test phase rotation before connection is made.

How to test the phase sequence

Step 1 Select the **VOLTAGE** function with the function selector switch. The following menu is displayed:

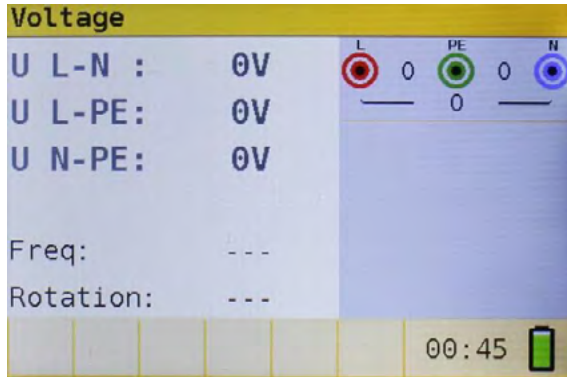

Figure 5.40: Phase rotation test menu

Step 2 Connect test cable to the ET6000 series instrument and follow the connection diagram shown in figure 5.41 to test phase sequence.

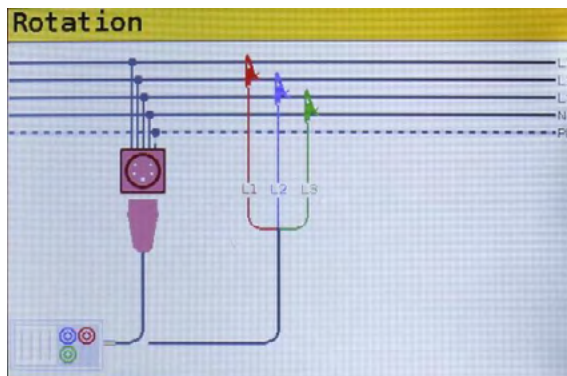

Figure 5.41: Connection of universal test cable and optional three phase cable

- Step 3** Check for warnings on the display and check the online voltage/terminal monitor. The phase sequence test is a continuously running test hence the results will be displayed as soon as the full test lead connection to the item under test has been made. All three-phase voltages are displayed in order of their sequence represented by the numbers 1, 2 and 3.

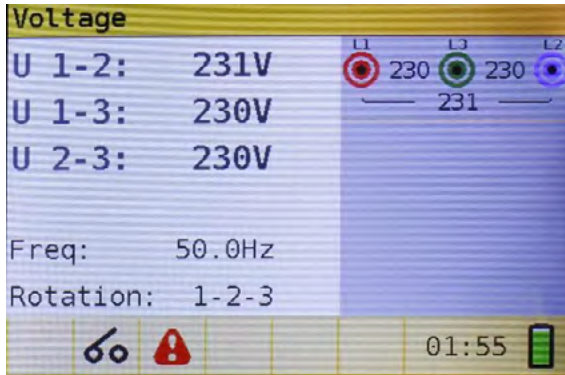

Figure 5.42: Example of phase sequence test result

Displayed results:

Freq	Frequency
Rotation	Phase sequence
-.-	Irregular rotation value

5.7 Voltage and frequency

Voltage measurements should be carried out regularly while dealing with electric installations (carrying out different measurements and tests, looking for fault locations, etc.). Frequency is measured for example when establishing the source of mains voltage (power transformer or individual generator).

How to perform voltage and frequency measurement

Step 1 Select the **VOLTAGE** function with the function selector switch. The following menu is displayed:

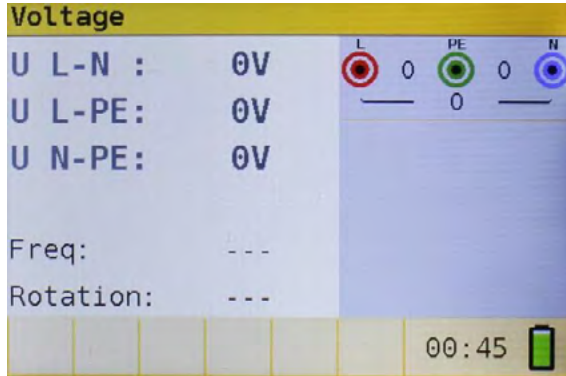

Figure 5.43: Voltage and frequency measurement menu

Step 2 Connect test cable to the ET6000 series instrument and follow the connection diagram shown in figure 5.44 to perform a voltage and frequency measurement.

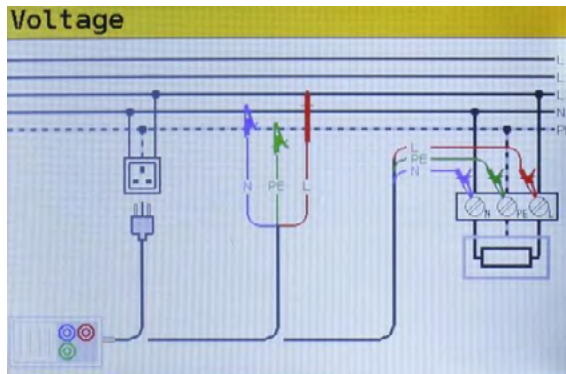

Figure 5.44: Connection diagram

- Step 3** Check the displayed warnings. The Voltage and Frequency test continually runs, showing fluctuations as they occur, these results are shown on the display during measurement.

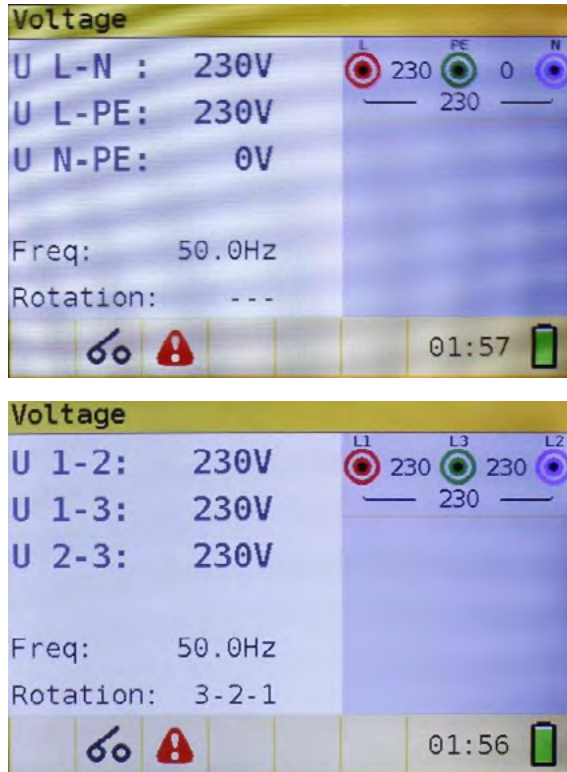

Figure 5.385: Examples of voltage and frequency measurements

Displayed results:

- U L-N** Voltage between phase and neutral conductors
- U L-PE** Voltage between phase and protective conductors
- U N-PE** Voltage between neutral and protective conductors

When testing three-phase system the following results are displayed:

- U 1-2** Voltage between phases L1 and L2
- U 1-3** Voltage between phases L1 and L3
- U 2-3** Voltage between phases L2 and L3

5.8 Earth Resistance (ET6500 only)

5.8.1 Earth Resistance (Re) - 3-wire, 4-wire Earth Spike Kit

The ET6500 model allows resistance to earth measurement using 3-wire and 4-wire measuring method. For 3-wire testing use the Martindale ER2KIT-S accessory and for 4-wire testing use the Martindale ER4KIT-S accessory.

How to perform Earth Resistance measurement

Step 1 Select the Earth Resistance function with the function selector switch and select the Re mode with the ▲▼ and ◀▶ navigation keys. The following menu will be displayed:

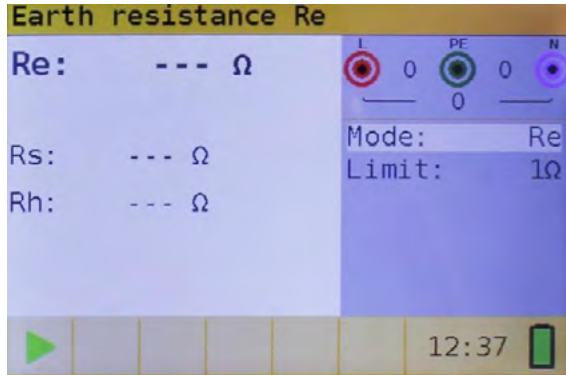

Figure 5.396: Earth Resistance (Re) measurement menu

Step 2 Set the following limit value:

- **Limit:** limit resistance value using the ▲▼ and ◀▶ navigation keys.

Step 3 Follow the connection diagram shown in figures 5.47 to perform the **Earth Resistance** measurement with 4 wires.

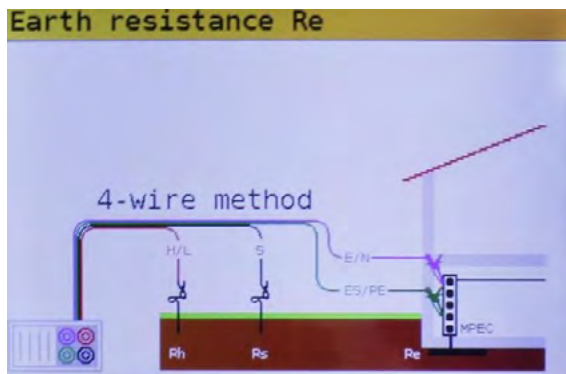

Figure 5.47: 4 wire connection diagram

Follow the connection diagram shown in figures 5.48 to perform the Earth Resistance measurement with 3 wires (ES connected to E).

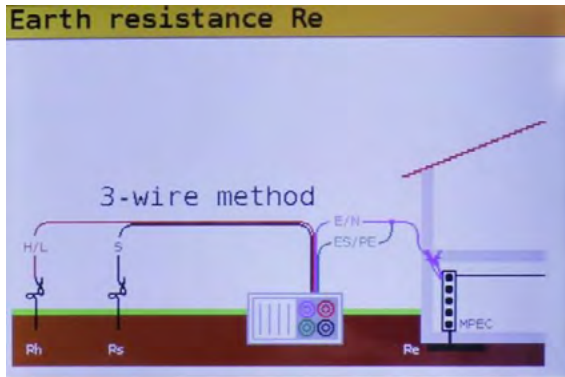





Figure 5.48: 3 wire connection diagram

Check for any warnings and the online voltage/terminal monitor on the display before starting the measurement. If everything is ok and the  is shown, press the **TEST** key.

After performing the measurement, the results appear on the display together with the  or  indication (if applicable).

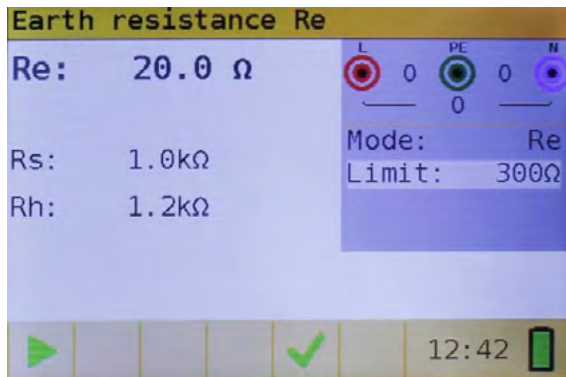

Figure 5.49: Example of resistance to earth measurement results

Displayed result:

- Re** Resistance to earth
- Rs** Resistance of S (potential) probe
- Rh** Resistance of H (current) probe

Notes:

- If a voltage of higher than 10V exists between test terminals, the Earth Resistance measurement will not be performed.

5.8.2 Specific earth resistance (Ro)

It is advisable to measure Earth Resistivity, when defining parameters of earthing system (required length and surface of earth electrodes, most appropriate depth of installing earthing system etc.) in order to reach more accurate calculations.

How to perform Specific Earth Resistance measurement

Step 1 Select the **Earth Resistance** function with the function selector switch and select the **Ro** mode with the \blacktriangle and \blacktriangleleft navigation keys. The following menu will be displayed:



Figure 5.50: Specific Earth Resistance (Ro) measurement menu

Step 2 Set the following limit value:

1. **Distance:** set distance “a” between test rods using the \blacktriangle and \blacktriangleleft navigation keys.

Step 3 Follow the connection diagram shown in figures 5.51 to perform the **Specific Earth Resistance** measurement.

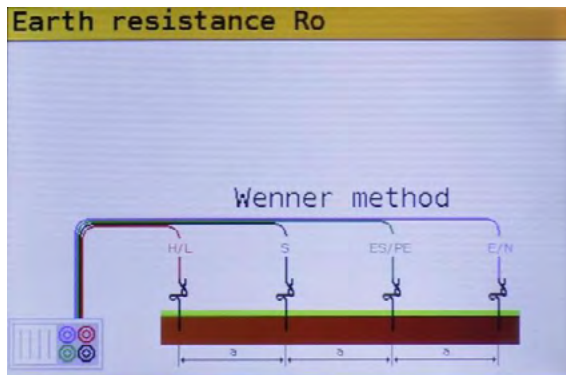



Figure 5.51: Connection diagram

Step 4 Check for any warnings and the online voltage/terminal monitor on the display before starting the measurement. If everything is ok and the  is shown, press the **TEST** key.



After performing the measurement, the results appear on the display together with the  or  indication (if applicable).



Figure 5.52: Example of specific earth resistance measurement results

Displayed result:

- Ro** Specific earth resistance
- Rs** Resistance of S (potential) probe
- Rh** Resistance of H (current) probe

Notes:

- If a voltage higher than 10V exists between test terminals, the Earth Resistance measurement will not be performed.

6 MAINTENANCE

6.1 Replacing fuses

There are three fuses under back battery cover of the ET6000 series instruments.

- **F3**

M 0.315 A / 250V, 20x5mm

This fuse protects internal circuitry of low-value resistance function if test probes are connected to the mains supply voltage by mistake.

- **F1, F2**

F 4 A / 500V, 32x6.3mm

General input protection fuses for the L/L1 and N/L2 test terminals.

Warnings:

- Disconnect any measuring accessory from the instrument and ensure that the instrument is turned off before opening the battery/fuse compartment cover, hazardous voltage can exist inside this compartment.
- Replace any blown fuses with exactly the same type of fuse. The instrument can be damaged and/or operator's safety impaired if this is not done!

The position of fuses can be seen in figure 3.4 in section 3.3 back panel, page 15.

6.2 Cleaning

If contamination is found, clean with a damp soft cloth and if necessary a mild detergent or alcohol. Do not use abrasives, abrasive solvents, or detergents which can cause damage to the unit. If a mild detergent is used, the unit should subsequently be thoroughly cleaned with a water dampened soft cloth. After cleaning, dry and allow to remain in a dry environment for 2 hours before use.

Warnings:

- Do not use liquids based on petrol or hydrocarbons.
- Do not spill cleaning liquid over the instrument.

6.3 Periodic calibration

To maintain the integrity of measurements made using your instrument, Martindale Electric recommends that it is returned at least once a year to an approved Calibration Laboratory for recalibration and certification.

Martindale Electric is pleased to offer you this service. Please contact our Service Department for details.

Email: service@martindale-electric.co.uk

Tel: +44 (0)1923 650 660

6.4 Service and storage conditions

For repairs under warranty, or at any other time, please contact your distributor. Unauthorized person(s) are not allowed to open the ET6000 series instruments.

There are no user replaceable components inside the instrument, except for the three fuses inside the battery compartment, refer to section 6.1 Replacing fuses.

Return to Martindale Electric if faulty. Our service department will quote promptly to repair any fault that occurs outside the guarantee period. Before the unit is returned, please ensure that you have checked the unit, batteries, leads and poor connections.

The instrument should be kept in warm dry conditions away from direct sources of heat or sunlight, and in such a manner as to preserve the working life of the unit. It is strongly advised that the unit is not kept in a toolbox where other tools may damage it.

6.5 Batteries

The ET6300 and ET6500 are supplied as standard with rechargeable batteries and a battery charger.

The ET6000 is supplied with standard alkaline batteries. To enable the ET6000 to be upgraded to be rechargeable the Martindale ETBATKIT is available which includes a set of rechargeable batteries and a charger. Never attempt to charge standard alkaline batteries in any ET series product.

- **Prevent Memory Effect**
Discharge and recharge the nickel-metal hydride batteries fully once in a while. This helps to keep the battery healthy by avoiding crystal development in discharged areas.
- **Exercise the Battery**
Do not leave the battery unused for a longer period. This allows crystals to develop, which reduces the battery's ability to hold a charge. A new battery break procedure should be applied to a dormant battery to regain its ability to work properly.
- **New Battery Break-in**
New batteries must be fully charged before use since they are bought in discharged conditions. It is essential to charge and discharge the battery completely so that it can regain its maximum rated capacity.

7 TECHNICAL SPECIFICATIONS

7.1 Insulation resistance

Insulation resistance (nominal voltages 50V DC)

Measurement range according to BS EN 61557 from 50k Ω -80M Ω

Measuring range (M Ω)	Resolution (M Ω)	Accuracy	
0.1 – 80.0	(0.100 ... 1.999)	0.001	\pm (5% of reading + 3 digits)
	(2.00 ... 80.00)	0.01	

Insulation resistance (nominal voltages 100V DC and 250V DC)

Measurement range according to BS EN 61557 from 100k Ω -199.9M Ω

Measuring range (M Ω)	Resolution (M Ω)	Accuracy	
0.1 – 199.9	(0.100 ... 1.999)	0.001	\pm (5% of reading + 3 digits)
	(2.00 ... 99.99)	0.01	
	(100.0 ... 199.9)	0.1	

Insulation resistance (nominal voltages 500 VDC and 1000V DC)

Measurement range according to BS EN 61557 from 500k Ω -199.9M Ω

Measuring range (M Ω)	Resolution (M Ω)	Accuracy	
0.1 – 199.9	(0.100 ... 1.999)	0.001	\pm (5% of reading + 3 digits)
	(2.00 ... 99.99)	0.01	
	(100.0 ... 199.9)	0.1	
200 – 999	(200 ... 999)	1	\pm (10% of reading)

Voltage

Measuring range (V)	Resolution (V)	Accuracy
0 – 1200	1	\pm (3% of reading + 3 digits)

Nominal voltages 50V DC, 100V DC, 250V DC, 500V DC, 1000V DC

Open circuit voltage -0% / +20% of nominal voltage

Measuring current min. 1mA at RN=UNx1k Ω /V

Short circuit current max. 15mA

The number of possible tests with a new set of batteries up to 1000 (with 2300mAh battery cells)

Auto discharge after test

If the instrument is exposed to damp the results could be impaired. In such case it is recommended to dry the instrument and accessories for at least 24 hours.

7.2 CONTINUITY RESISTANCE

7.2.1 Low R (ET6300 & ET6500)

Measuring range according to EN61557-4 is 0.1Ω – 1999Ω.

Measuring range (Ω)	Resolution (Ω)	Accuracy
0.1 – 20.0	(0.10Ω ... 19.99Ω) 0.01Ω	±(3% of reading + 3 digits)
20.0 – 1999	(20.0Ω ... 99.9Ω) 0.1Ω (100Ω ... 1999Ω) 1Ω	±(5% of reading)

Open-circuit voltage	5 V DC
Measuring current	min. 200mA into load resistance of 2Ω
Test lead compensation	up to 5Ω
The number of possible tests with a new set of batteries	up to 1400 (with 2300mAh battery cells)
Automatic polarity reversal of the test voltage	

7.2.2 Low current continuity (ET6300 & ET6500 Only)

Measuring range (V)	Resolution (V)	Accuracy
0.1 – 1999	(0.1 Ω ... 99.9Ω) 0.1Ω (100.0 Ω ... 1999Ω) 1Ω	±(5% of reading + 3 digits)

Open-circuit voltage	5V DC
Short-circuit current	max. 7 mA
Test lead compensation	up to 5 Ω

7.3 RCD testing

7.3.1 General data

Nominal residual current	6mA*, 10mA, 30mA, 100mA, 300mA, 500mA, 650mA*, 1000 mA*
Nominal residual current accuracy	-0 / +0.1·I _Δ ; I _Δ = I _{ΔN} , 2xI _{ΔN} , 5xI _{ΔN} -0.1·I _Δ / +0; I _Δ = ½xI _{ΔN}
Test current shape	Sine-wave (AC), DC (B), pulsed (A)*
RCD type	general (G, non-delayed), selective (S, time-delayed), EVSE*
Test current starting polarity	0° or 180°
Voltage range	93V-134V; 185V-266V; 45Hz-65Hz
(*ET6300 & ET6500 only)	

RCD test current selection (r.m.s. value calculated to 20 ms) according to IEC 61009:

$I_{\Delta N}$ (mA)	$\frac{1}{2}xI_{\Delta N}$			$1xI_{\Delta N}$			$2xI_{\Delta N}$			$5xI_{\Delta N}$			RCD I_{Δ}		
	AC	A	B	AC	A	B	AC	A	B	AC	A	B	A C	A	B
6*	3	2.1	3	6	12	12	12	24	24	30	60	60	✓	✓	✓
10	5	3.5	5	10	20	20	20	40	40	50	100	100	✓	✓	✓
30	15	10.5	15	30	42	60	60	84	120	150	212	300	✓	✓	✓
100	50	35	50	100	141	200	200	282	400	500	707	1000	✓	✓	✓
300	150	105	150	300	424	600	600	848	n/a	1500	n/a	n/a	✓	✓	✓
500	250	175	250	500	707	1000	1000	1410	n/a	2500	n/a	n/a	✓	✓	✓
650*	325	228	325	650	919	1300	1300	n/a	n/a	n/a	n/a	n/a	✓		
1000*	500	350	500	1000	1410	n/a	2000	n/a	n/a	n/a	n/a	n/a	✓		

(na) not available / (*ET6300 & ET6500)

7.3.2 Contact voltage

Measuring range according to BS EN 61557-6 is 3.0 V – 49.0V f. limit contact voltage 25V.

Measuring range according to BS EN 61557-6 is 3.0 V – 99.0V for limit contact voltage 50V.

Measuring range (V)	Resolution (V)	Accuracy
3.0 – 9.9	0.1	(-0%/+10%) of reading + 5 digits
10.0 – 99.9	0.1	(-0%/+10%) of reading + 5 digits

Test current max. $0.5xI_{\Delta N}$

Limit contact voltage 25V, 50V

Fault loop resistance at contact voltage is calculated as
$$R_L = \frac{U_C}{I_{\Delta N}}$$

7.3.3 Trip-out time

Complete measurement range corresponds to BS EN 61557-6 requirements. Specified accuracies are valid for complete operating range.

Measuring range (V)	Resolution (V)	Accuracy
0.0 – 500.0	0.1	±3 ms

Test current $\frac{1}{2}xI_{\Delta N}$, $I_{\Delta N}$, $2xI_{\Delta N}$, $5xI_{\Delta N}$

7.3.4 Trip-out current

Measurement range corresponds to BS EN 61557-6 for $I_{\Delta N} \geq 10\text{mA}$. Specified accuracies are valid for complete operating range.

Measuring range I_{Δ}	Resolution I_{Δ}	Accuracy
$0.2 \times I_{\Delta N} - 1.1 \times I_{\Delta N}$ (AC type)	$0.05 \times I_{\Delta N}$	$\pm 0.1 \times I_{\Delta N}$
$0.2 \times I_{\Delta N} - 1.5 \times I_{\Delta N}$ (A type, $I_{\Delta N} \geq 30\text{ mA}$)	$0.05 \times I_{\Delta N}$	$\pm 0.1 \times I_{\Delta N}$
$0.2 \times I_{\Delta N} - 2.2 \times I_{\Delta N}$ (A type, $I_{\Delta N} = 10\text{ mA}$)	$0.05 \times I_{\Delta N}$	$\pm 0.1 \times I_{\Delta N}$
$0.2 \times I_{\Delta N} - 2.2 \times I_{\Delta N}$ (B type)	$0.05 \times I_{\Delta N}$	$\pm 0.1 \times I_{\Delta N}$

Trip-out time

Measuring range (ms)	Resolution (ms)	Accuracy
0 – 300	1	$\pm 3\text{ ms}$

Contact voltage

Measuring range (V)	Resolution (V)	Accuracy
3.0 – 9.9	0.1	(-0%/+10%) of reading + 5 digits
10.0 – 99.9	0.1	(-0%/+10%) of reading + 5 digits

7.4 Fault loop impedance and prospective fault current

Zloop L-PE, I_{pfC} sub-function

Measuring range according to BS EN 61557-3 is 0.25Ω – 1999Ω.

Measuring range (Ω)	Resolution (Ω)	Accuracy
0.2 – 9999	(0.20 ... 19.99)	0.01
	(20.0 ... 99.9)	0.01
	(100... 9999)	1
		±(5% of reading + 5 digits)

Prospective fault current (calculated value)

Measuring range (A)	Resolution (A)	Accuracy
0.00 – 19.99	0.01	Consider accuracy of fault loop resistance measurement
20.0 – 99.9	0.1	
100 – 999	1	
1.00k – 9.99k	10	
10.0 – 100.0k	100	

Test current (at 230V) 3.4A, 50Hz Sine wave ($10\text{ms} \leq t_{\text{LOAD}} \leq 15\text{ms}$)

Nominal voltage range 93V – 134V; 185V – 266V (45Hz – 65Hz)

Zloop L-PE RCD and Rs, I_{pf}, non trip subfunction

Measuring range according to BS EN 61557 is 0.75Ω – 1999Ω.

Measuring range (Ω)	Resolution (Ω)	Accuracy*
0.4 – 19.99	(0.40 ... 19.99) 0.01	±(5% of reading + 10 digits)
20.0 – 9999	(20.0 ... 99.9) 0.01 (100 ... 9999) 1	±10% of reading

*Accuracy may be impaired in case of heavy noise on mains voltage.

Prospective fault current (calculated value)

Measuring range (A)	Resolution (A)	Accuracy
0.00 – 19.99	0.01	Consider accuracy of fault loop resistance measurement
20.0 – 99.9	0.1	
100 – 999	1	
1.00k – 9.99k	10	
10.0 – 100.0k	100	

No trip out of RCD.

Nominal voltage range 93V – 134V; 185V – 266V (45Hz – 65Hz)

7.5 Line impedance and prospective short-circuit current

Line impedance

Measuring range according to BS EN 61557-3 is $0.25\Omega - 1999\Omega$.

Zline L-L, L-N, I_{psc} subfunction

Measuring range (Ω)	Resolution (Ω)	Accuracy
0.2 – 9999	(0.20 ... 19.99)	0.01
	(20.0 ... 99.9)	0.01
	(100... 9999)	1
		$\pm(5\%$ of reading + 5 digits)

Prospective short-circuit current (calculated value)

Measuring range (A)	Resolution (A)	Accuracy
0.00 – 19.99	0.01	Consider accuracy of line resistance measurement
20.0 – 99.9	0.1	
100 – 999	1	
1.00k – 9.99k	10	
10.0 – 100.0k	100	

Test current (at 230V) 3.4A, 50Hz Sine wave ($10\text{ms} \leq t_{LOAD} \leq 15\text{ms}$)

Nominal voltage range 93V–134V; 185V–266V; 321V–485V (45Hz – 65Hz)

Voltage drop:

Measuring range (%)	Resolution (%)	Accuracy
0.00 – 9.9	0.1	Consider accuracy of the line measurement (only calculated value)

7.6 Phase rotation

Measuring according to BS EN 61557-7

Nominal mains voltage range	50 V _{AC} – 550V _{AC}
Nominal frequency range	45 Hz – 400Hz
Result displayed	Right:1-2-3 ; Left: 3-2-1

7.7 Voltage and frequency

Measuring range (V)	Resolution (V)	Accuracy
0 – 550	1	±(2% of reading + 2 digits)

Frequency range 0 Hz, 45Hz – 400Hz

Measuring range (Hz)	Resolution (Hz)	Accuracy
10 – 499	0.1	±0.2% + 1 digit

Nominal voltage range 10V – 550V

7.8 Earth Resistance (ET6500 Only)

Measuring range according to BS EN 61557-5 is 100Ω – 1999Ω.

Re – Earth resistance, 3-wire, 4-wire

Measuring range (Ω)	Resolution (Ω)	Accuracy
1.0 – 9999	(1.00 ... 19.99)	0.01
	(20.0 ... 199.9)	0.1
	(100... 9999)	1
		±(5% of reading + 5 digits)

Max. auxiliary earth electrode resistance Rh 100xRE or 50 kΩ (whichever is lower)

Max. probe resistance Rs 100xRE or 50 kΩ (whichever is lower)

Rh and Rs values are indicative.

Additional probe resistance error at Rhmax or Rsmax ±(10% of reading + 10 digits)

Additional error at 3V voltage noise (50 Hz) ±(5% of reading + 10 digits)

Open circuit voltage	< 30V AC
Short circuit current	< 30mA
Test voltage frequency	126.9Hz
Test voltage shape	sine wave

Automatic measurement of auxiliary electrode resistance and probe resistance.

Ro - Specific earth resistance

Measuring range (A)	Resolution (A)	Accuracy
6.0 Ωm ... 99.9 Ωm	0.1 Ωm	±(5% of reading + 5 digits)
100 Ωm ... 999 Ωm	1 Ωm	±(5% of reading + 5 digits)
1.00 kΩm ... 9.99 kΩm	0.01 kΩm	±(10% of read.) for Re 2kΩ...19.99kΩ
10.0 kΩm ... 99.9 kΩm	0.1 kΩm	±(10% of read.)for Re 2kΩ...19.99kΩ
100 kΩm ... 9999 kΩm	1 kΩm	±(20% of read.) for Re > 20kΩ

Principle: $R = 2 \cdot \pi \cdot d \cdot Re$, where Re is a measured resistance in 4-wire method and d is distance between the probes.

Rh and Rs values are indicative.

7.9 General data

Power supply voltage	9V DC (6x1.5 V battery cells, size AA)
Power supply adapter	12V DC / 1000 mA
Battery charging current	< 600 mA (internally regulated)
Voltage of charged batteries	9 V DC(6x1.5V, at fully charged state)
Charging duration time	Typical 6h
Operation	Typical 15h

Overvoltage category	CAT III 600V, CAT IV 300V
Location	Suitable for indoor use and outdoor use in dry weather conditions only

Altitude	Up to 2000m
Protection classification	Class II, double insulation
Pollution degree	2
Protection degree	IP2X

Display	480x320 TFT LCD
---------	-----------------

COM-Port	USB-B
----------	-------

Dimensions (w x h x d)	25cm x 10.7cm x 13.5cm
Weight (without battery)	1.30kg

Reference conditions	
Reference temperature range	10°C – 30°C
Reference humidity range	40% RH – 70% RH

Operating conditions	
Working temperature range	0°C – 40°C
Maximum relative humidity	95% RH (0°C – 40°C), non-condensing

Storage conditions	
Temperature range	-10°C – +70°C
Maximum relative humidity	90% RH (-10°C – +40°C) 80% RH (40°C – 60°C)

The error in operating conditions could be at most the error for reference conditions (specified in the manual for each function) + 1% of measured value + 1 digit unless otherwise specified.

8 STORING MEASUREMENTS (ET6500 ONLY)

After the measurement is completed, results can be stored in internal memory of the instrument together with the sub-results and function parameters.

8.1 Overview

- The ET6500 instrument can store up to 1000 measurements
- The list of records can be stepped through
- A single record or all records can be deleted
- Numeric ID's for customer, location and object can be edited

If there is no actual measurement made and the **MEM** key is pressed and there are no records stored, an empty memory screen is displayed (Figure 8.2).

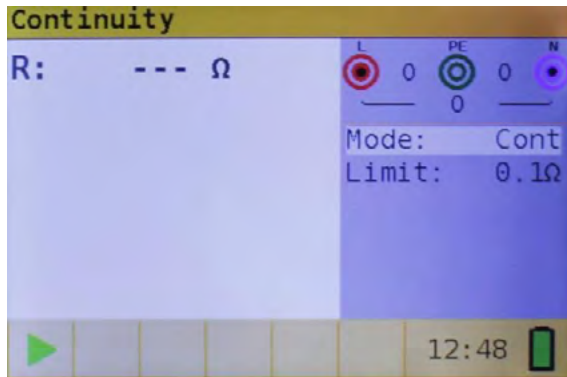

Figure 8.1: no result

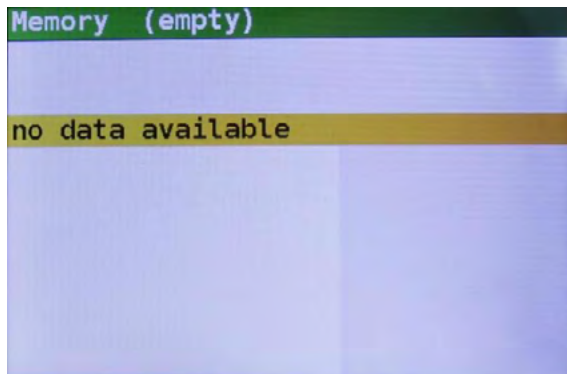

Figure 8.2: empty memory

8.2 Saving results

Step 1 When the measurement is finished (Figure 8.3) results are displayed on the screen.

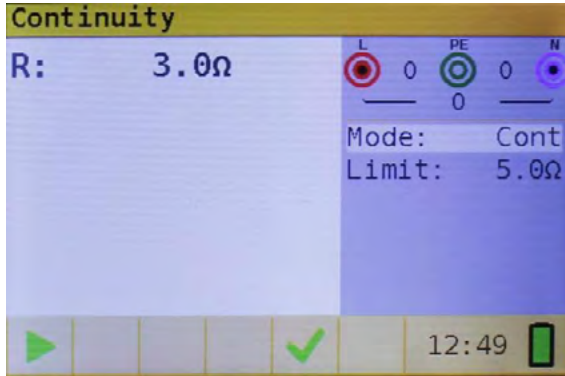

Figure 8.3: Last results

Step 2 Press the **MEM** key. The following is displayed (Figure 8.4):

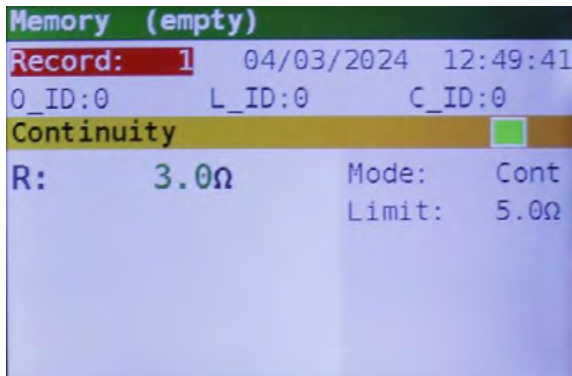

Figure 8.4: Save results

- Next record number in red letters
- Current date (day/month/year)
- Time (hour:minutes:seconds)
- Object ID
- Location ID
- Customer ID
- Measurement function
- Measurement Results
- Measurement Mode
- Measurement Limit

- Step 3** The object ID, location ID and customer ID are stored as individual numbers between 0 and 65535. To change these, press the **LEFT** key. The following screen will be displayed (Figure 8.5).

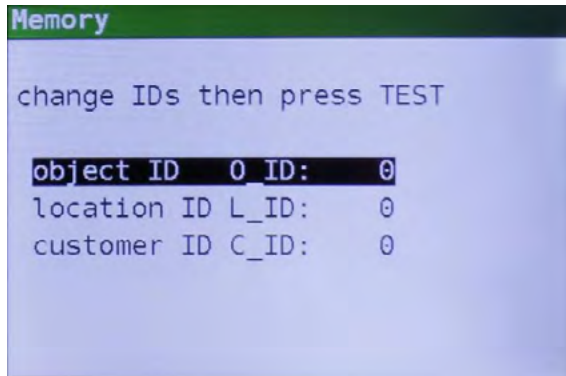

Figure 8.5: ID editor

Use the ▲▼ navigation keys to choose the ID type and the ◀▶ navigation keys to change the value of the ID.

The object, location and customer ID are stored as individual numbers between 0 and 65535.

Press the **Exit/Back/Return** key to return to the record screen without changing the IDs.

Press **TEST** to save the IDs in the actual record. These IDs will also be used for the following new records.

- Step 4** To store the result of last measurement, press **TEST** key. The following will be displayed (Figure 8.6).

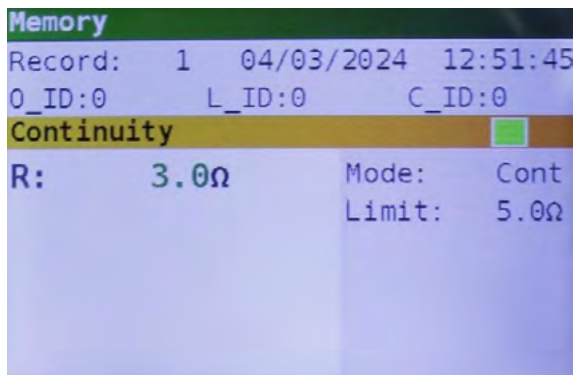

Figure 8.6: Saved results

The record number will change from red to black letters. That means that this result will be saved in memory as record 1.

Each single result can be shown in coloured letters:

- Green: measured and passed
- Red: measured but failed
- Black: measured but not judged

In addition, the blue function bar contains a coloured field that shows the overall result of the measurement:

- Green: measured and passed
- Red: measured but failed
- Brown: measured but not judged

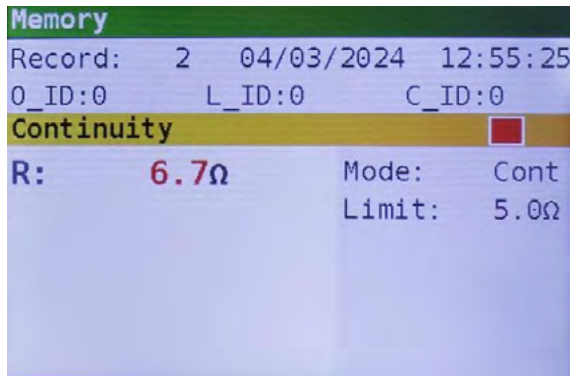

Figure 8.7: failed result

To cancel the saving of the record press **MEM** or **Exit / Back / Return** key instead of **TEST**, the last measurement screen is then shown.

Step 5 Press the **MEM** or **Exit / Back / Return** key to return to last measurement screen or the **▲▼** navigation keys to see a record from the list.

8.3 Recalling results

Step 1 To enter the Memory screen press the **MEM** key.
When no measurement was made, the last record is directly shown.
When a measurement was made, a screen as in figure 8.4 is shown. Press the UP ▲ or DOWN ▼ key to enter the record list.

Step 2 Press the UP ▲ or DOWN ▼ key to step through the records.

It is possible to change the IDs of an existing record. Press the LEFT key to enter the ID editor, change the IDs and save it. Edited IDs will not be carried forward to any following new records.

8.4 Deleting results

Step 1 To enter the Memory screen press the **MEM** key.
When no measurement was made, the last record is directly shown.
When a measurement was made, a screen as in figure 8.4 is shown. Press then the UP ▲ or DOWN ▼ key to enter the record list.

Step 2 Press the UP ▲ or DOWN ▼ key to find the record that has to be deleted.

Step 3 Press the RIGHT ► key, the following screen will be displayed (Figure 8.8).

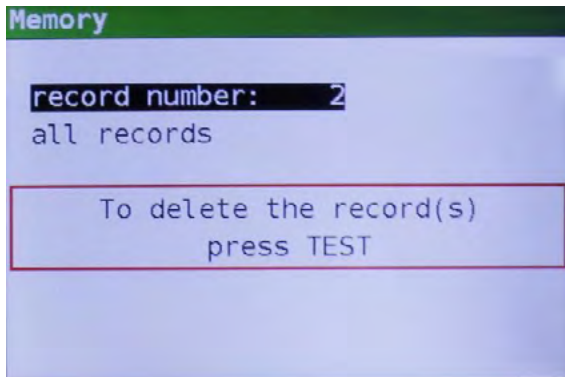

Figure 8.8: delete screen

Step 4 Press the **TEST** key to delete the selected record and return to the record list
or

Step 5 Press the DOWN ▼ key to select all records (Figure 8.9)

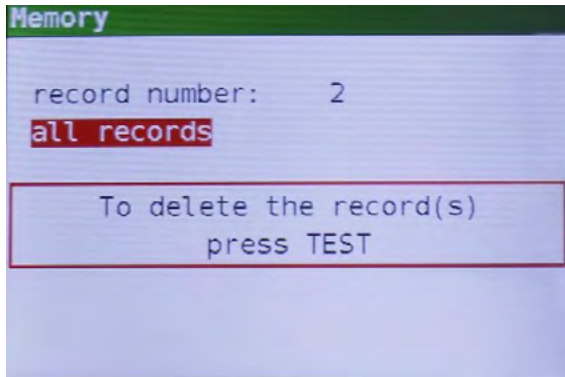

Figure 8.8: delete screen

Then press the **TEST** key to delete all records and return to the measurement screen.

When a single record is deleted, its space in memory is freed and can be reused. The record number of the deleted record however is not used for new records.

When all records are deleted, the complete memory space is freed and all IDs and numbers are reset.

9 TEST RESULT DOWNLOAD (ET6500 ONLY)

9.1 MFT Records - PC software

Stored results from the Martindale ET6500 can be downloaded to a PC using the MFT Records application for additional activities such as simple report creation and/or further analysis in an Excel spreadsheet.

9.2 Downloading records to PC

Test records are exported from the ET6500 and stored on PC in form of a .csv file via MFT Records and are saved. These can then be exported from the application to a standard Excel spreadsheet (*.xlsx) for quick generation of reports and if required, for further analysis.

1. ET6500 connection to the PC is via the standard USB port on the topside of the of the housing using the supplied USB connection cable.-

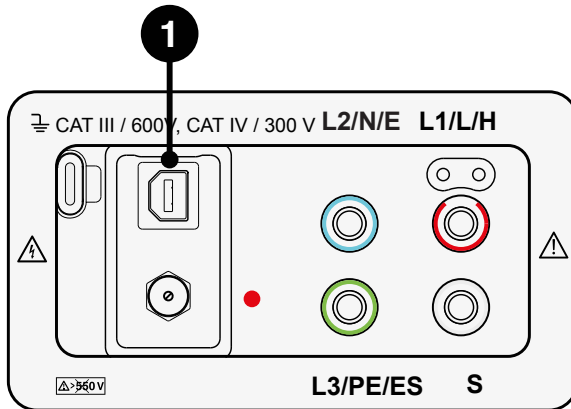

The MFT Records application available to download from the Martindale website:

www.martindale-electric.co.uk/MFTRecords

The user manual for the MFT Records software with full instructions on installation and use of the application is also available:

www.martindale-electric.co.uk/MFTRecordsManual

10 WARRANTY AND LIMITATION OF LIABILITY

This Martindale product is warranted to be free from defects in material and workmanship under normal use and service. The warranty period is 2 years and begins on the date of receipt by the end user. This warranty extends only to the original buyer or end-user customer, and does not apply to fuses, disposable batteries, test leads or to any product which, in Martindale's reasonable opinion, has been misused, altered, neglected, contaminated, or damaged by accident or abnormal conditions of operation, handling or storage.

Martindale authorised resellers shall extend this warranty on new and unused products to end-user customers only but have no authority to extend a greater or different warranty on behalf of Martindale.

Martindale's warranty obligation is limited, at Martindale's option, to refund of the purchase price, free of charge repair, or replacement of a defective product which is returned to Martindale within the warranty period.

This warranty is the buyer's sole and exclusive remedy and is in lieu of all other warranties, expressed or implied, including but not limited to any implied warranty of merchantability or fitness for a particular purpose. Martindale shall not be liable for any special, indirect, incidental or consequential damages or losses, including loss of data, arising from any cause or theory.

Since some jurisdictions do not allow limitation of the term of an implied warranty, or exclusion or limitation of incidental or consequential damages, the limitations and exclusions of this warranty may not apply to every buyer. If any part of any provision of this warranty is held invalid or unenforceable by a court or other decision-maker of competent jurisdiction, such holding will not affect the validity or enforceability of any other provision or other part of that provision.

Nothing in this statement reduces your statutory rights.

INSTALLATION CATEGORIES

CAT Ratings

BS EN 61010-1 Installation Categories (CAT ratings) define the risks from hazardous transient impulses and potentially lethal short circuit currents on the mains supply system based on where you are working.

Voltage Ratings

Test equipment used for measuring mains circuits will have a CAT rating to show where it can be used. Each category also has a voltage rating to show the maximum safe phase to earth system voltage, normally 50V, 100V, 150V, 300V, 600V or 1000V.

Stay safe - Match your test equipment safety rating to the installation category.

CAT II: Socket outlets and similar points of the mains installation.

CAT III: The distribution part of the building's mains installation.

CAT IV: The supply side source of the building's mains installation.

Testers, leads and accessories all need safety ratings equivalent to, or higher than the installation category and voltage rating for the location to be safe.

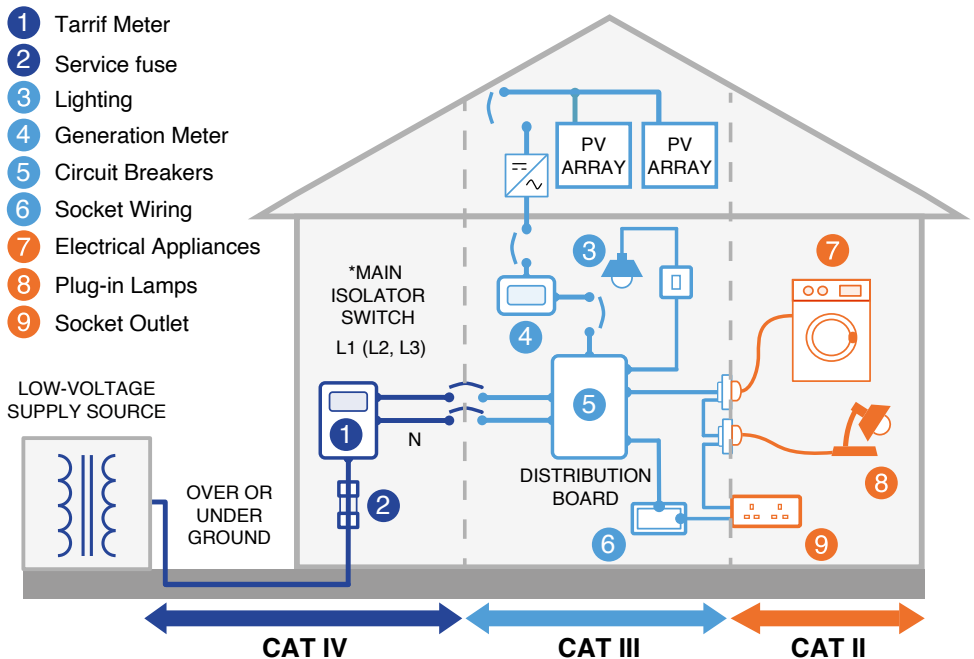

Check out what else you can get from Martindale:

- 18th Edition Testers
- Accessories
- Cable Locators
- Calibration Equipment
- Continuity Testers
- Digital Clamp Meters
- Digital Multimeters
- Electricians' Kits
- Environmental Products
- Full Calibration & Repair Service
- Fuse Finders
- Labels
- Microwave Leakage Detectors
- Multifunction Testers
- PAT Testers & Accessories
- Phase Rotation Testers
- Proving Units
- Safe Isolation Kits
- Socket Testers
- Specialist Drummond Testers
- Thermometers & Probes
- Test Leads
- Voltage Indicators

Martindale Electric Co. Ltd. Metrohm House,
12 Imperial Park, Imperial Way, Watford WD24 4PP. T: +44 (0)1923 441717
www.martindale-electric.co.uk sales@martindale-electric.co.uk

Ver. E1.7

Due to policy of continuous development, Martindale Electric reserves the right to alter equipment specification and description outlined in this document without prior notice. No part of this document shall be deemed to be part of any contract for the equipment unless specifically referred to as an inclusion within such contract. © 2024 Martindale Electric Co. Ltd. Registered in England No. 3387451. LITET6000