

# MM94 TRMS DIGITAL MULTIMETER

## Instruction Manual

---



**MARTINDALE**  
● ● ● ELECTRIC

*Keeping You Safe*



## **ALWAYS READ THESE INSTRUCTIONS BEFORE PROCEEDING**

Thank you for using one of our products. For safety and a full understanding of its benefits please read this manual before use. Technical support is available from 01923 441717 and [support@martindale-electric.co.uk](mailto:support@martindale-electric.co.uk)

### **CONTENTS**

<b>1</b>	<b>Safety Information</b>	<b>1</b>
1.1	Meaning of Symbols and Markings	1
1.2	Precautions	2
<b>2</b>	<b>Introduction</b>	<b>4</b>
2.1	Inspection	4
2.2	Description	5
2.3	Accessories	5
<b>3</b>	<b>Operation</b>	<b>6</b>
3.1	General	6
3.2	Low Battery Indication	6
3.3	Description of Terminals	6
3.4	Description of Press Buttons	7
3.5	Description of LCD Symbols	7
3.6	Auto Power Off	9
3.7	Backlight	9
3.8	Auto / Manual Ranging	9
3.9	Relative Function	9
3.10	Min / Max	10
3.11	Display Hold	10
3.12	High Frequency Rejection	11

3.13	Use of the TL16 Test Leads	11
3.14	AC Voltage Measurements	11
3.15	DC Voltage Measurements	12
3.16	AC+DC Voltage Measurements	12
3.17	Current Measurements	12
3.18	Peak Hold Measurement	13
3.19	Resistance Measurements	13
3.20	Conductance Measurements	13
3.21	Capacitance Measurements	14
3.22	Frequency and Duty Cycle Measurements	14
3.23	Temperature Measurements	15
3.24	Continuity Testing	15
3.25	Diode Testing	16
<b>4</b>	<b>Maintenance</b>	<b>16</b>
4.1	Battery Replacement	16
4.2	Fuse Replacement	17
4.3	Test Lead Replacement	17
4.4	Calibration	17
4.5	Cleaning	18
4.6	Repair & Service	18
4.7	Storage Conditions	18
<b>5</b>	<b>Warranty</b>	<b>19</b>
	<b>Measurement Categories</b>	<b>20</b>
	<b>Specifications</b>	

## 1. SAFETY INFORMATION: Always read before proceeding.

### REMEMBER: SAFETY IS NO ACCIDENT

These instructions contain both information and warnings that are necessary for the safe operation and maintenance of this product. It is recommended that you read the instructions carefully and ensure that the contents are fully understood. Failure to understand and to comply with the warnings and instructions can result in serious injury, damage or even death.

Particular attention should be paid to the Warnings, Precautions and Technical Specifications.

Please keep these instructions for future reference. Updated instructions and product information are available at:

[www.martindale-electric.co.uk](http://www.martindale-electric.co.uk)

### 1.1 Meaning of Symbols and Markings

 **Caution - risk of danger & refer to instructions**

 **Caution - risk of electric shock**

 **Equipment protected by double or reinforced insulation (Class II)**

**CAT II (Measurement Category II)** is applicable to test and measuring equipment connected directly to utilization points (socket outlets and similar points) of the low-voltage MAINS installation.

**CAT III (Measurement Category III)** is applicable to test and measuring equipment connected to the distribution part of the building's low-voltage MAINS installation.

**CAT IV (Measurement Category IV)** is applicable to test and measuring equipment connected at the source of the building's low-voltage MAINS installation.

For further information on measurement categories see page 20 or visit:  
[www.martindale-electric.co.uk/measurement\\_categories.php](http://www.martindale-electric.co.uk/measurement_categories.php)



**Equipment complies with relevant EU Directives**



**Equipment complies with relevant UK conformity**



**End of life disposal of this equipment should be in accordance with relevant EU Directives.**

## 1.2 Precautions

This product has been designed with your safety in mind, but please pay attention to the following warnings and cautions before use.

### **Warnings**

In order to avoid the danger of electrical shock, it is important that proper safety measures are taken when working with voltages exceeding the extra low voltage (ELV) limit of 50V (25V) RMS AC or 120V (60V) DC. The values in brackets apply to restricted voltage ranges (for example, in the medical or agricultural sector).

Where applicable other safety measures such as the use of protective gloves, goggles etc. should be employed.

The multimeter must only be used by a skilled and competent person who is familiar with the relevant regulations, the safety risks involved and the consequent normal safe working practices, and under the conditions and for the purposes for which it has been constructed and specified.

Before each use the multimeter and any associated test leads and accessories should be examined for damage, cracks, cuts or scratches. **Do not use** if damaged in any way.

Make sure the multimeter and test leads are dry, clean and free from dust, grease and moisture while in use to avoid the danger from electric shock due to surface leakage.

Always test this unit on an appropriate proving device or a known good voltage source before and after using it to determine if a hazardous voltage exists in a circuit to be tested. **Do not use** the unit if it does not function correctly during proving.

Measuring/testing for a voltage/current that exceeds the specified limits of the unit may damage the unit and may expose the operator to a shock hazard. Always check the unit's specified limits before use.

The multimeter must only be used on CAT IV installations up to 600V to earth, CAT III and CAT II installations up to 1000V to earth, and within the operating temperature and humidity range specified.

The CAT III 1000V marking does not mean the multimeter can be used to 1000V AC rms, but that it will be safe to the user if inadvertently connected across a voltage up to 1000V AC rms to earth.

If the removable probe tip caps are not fitted to the probes of the test leads, their measurement category becomes CAT II 1000V, and they **must not be used** on CAT III or CAT IV installations to avoid the risk of shorting high energy circuits and arc flash.

When this unit is used in combination with test leads, the measurement category of the combination is the lower measurement

category of either this unit or the test leads used.

Likewise if test lead accessories such as crocodile clips are also used, the measurement category will be the lowest measurement category in that combination.

**Do not use** if the battery compartment cover is not fitted.

When using test leads, **always** keep your fingers behind the finger guard on the test lead probe.

To avoid electrical shock, and damage to the multimeter, do not use the multimeter and the associated temperature probe when voltages at the measurement surface exceed 30V AC rms or 60V DC.

### **Cautions**

Avoid severe mechanical shock or vibration and extreme temperature.

When using test leads avoid excessive stresses to the cable entry points at the probe and 4mm plug connector.

To avoid burns or damage to equipment, do not take temperature measurements inside microwave ovens.

To avoid possible corrosion from a leaking battery, remove the battery when the unit is not in use for an extended period.

## **2. INTRODUCTION**

### **2.1 Inspection**

Examine the shipping carton for any sign of damage. Inspect the unit and any accessories for damage. If there is any damage then consult your distributor immediately.

## 2.2 Description

The Martindale MM94 has the following measurement functions:

- True rms AC voltage to 750V
- DC voltage to 1000V
- True rms AC current to 20A
- DC current to 20A
- Resistance to 60M $\Omega$
- Conductance to 60nS
- Capacitance to 6mF
- Frequency to 10MHz
- Duty cycle
- Temperature (Type K thermocouple)
- Continuity with audible indication
- Diode testing

Further functions are:

- Display hold
- Min/Max indication
- Peak hold measurement
- Selectable high frequency rejection
- Relative function
- Selectable 6000 or 60000 count display
- Display backlight
- Auto or manual ranging
- Auto power off

## 2.3 Accessories

The MM94 comes with the following accessories:

- TL16 test leads
- TT1P Type K thermocouple
- 9V PP3 battery (Installed)
- Instructions

### 3. OPERATION

#### 3.1 General

If the magnitude of a parameter to be measured is uncertain, but known to be within the maximum safe limits of the electrical tester, manually set the range to maximum. E.g. If measuring AC voltage and the voltage magnitude is unknown, set the range to 750 V, then if required select the correct range for a satisfactory reading.

If the insulation multimeter displays **OL** or **-OL** then the measurement limits of the range have been exceeded.

#### 3.2 Low Battery Indication

The battery capacity is shown by one of the following symbols on the LCD: 

If the  symbol is displayed, the battery needs replacing as measurement accuracy can no longer be guaranteed (See section 4.1 Battery Replacement). This will be followed by a **bAtt** display and the multimeter will power down after 5 seconds.

#### 3.3 Description of Terminals





<b>20A</b>	Input terminal for AC & DC current measurements to 20A
<b>μA mA</b> ←	Input terminal for AC & DC current measurements to 400 mA
<b>COM</b>	Common terminal
<b>nsHz%</b> <b>V Ω</b> →	Input terminal for AC and DC voltage, resistance, conductance, continuity, diode test, frequency and duty cycle
<b>K-TYPE</b>	Input terminals for temperature probes

### 3.4 Description of Press Buttons

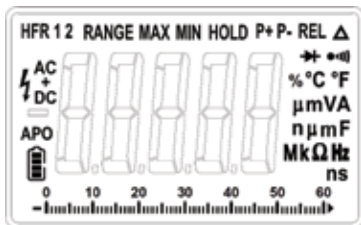
<b>RANGE</b>	Selects manual ranging
<b>REL <math>\Delta</math></b>	Selects relative function
<b>MINzMAX</b>	Selects min / max function
<b>HOLD</b>	Selects display hold function
<b>PEAK <math>\pm</math> cal&gt;2s</b>	Selects peak hold measurement
	Turns on/off the backlight
<b>SHIFT</b>	Selects secondary functions
<b>HFR</b>	Selects -3db point of high frequency rejection filter
<b>6000</b>	Sets display to 6000 counts

### 3.5. Description of LCD Symbols



<b>HFR1</b>	High frequency reject > 1 kHz selected
<b>HFR 2</b>	High frequency reject > 100 kHz selected
<b>RANGE</b>	Manual ranging is selected
<b>MAX</b>	Maximum indication is displayed
<b>MIN</b>	Minimum indication is displayed
<b>HOLD</b>	Display hold is activated
<b>P+</b>	Indicates peak + measurement
<b>P-</b>	Indicates peak - measurement
<b>REL <math>\Delta</math></b>	Relative function selected
	Indicates >30V at input terminals
<b>AC</b>	Indicates AC measurement
<b>DC</b>	Indicates DC measurement
<b>AC + DC</b>	Indicates AC + DC measurement
<b>APO</b>	Auto power off is activated
	Indicates battery level
	Diode testing function is selected
	Continuity function is selected
<b>mV, V, <math>\mu</math>A, mA, A, nF, <math>\mu</math>F, mF, <math>\Omega</math>, k<math>\Omega</math>, M<math>\Omega</math>, nS, Hz, kHz, MHz, %, <math>^{\circ}</math>C, <math>^{\circ}</math>F</b>	Units of measurement being displayed

### 3.6 Auto Power Off

If the multimeter is inactive for a period of 30 minutes it will automatically power off.

If any button is pressed after the multimeter has automatically powered off, the multimeter will turn back on.

To disable the auto power off function hold the **MIN/MAX** button at the same time as turning the rotary switch from **OFF** to any position.

The **APO** symbol will no longer be displayed on the LCD.

### 3.7 Backlight

To switch on the backlight press the  button. Press again to turn the backlight off.

The backlight will automatically power off after approx. 3 minutes.

### 3.8 Auto/Manual Ranging

To select manual ranging, press the **RANGE** button. The **RANGE** symbol will be displayed on the LCD.

To manually select a range when in manual mode press the **RANGE** button until the required range is selected.

To exit manual ranging, hold down the **RANGE** button for >2 seconds. The **RANGE** symbol will no longer be displayed.

### 3.9 Relative Function

The relative function is used to remove an offset or residual value from a measurement.

To remove and store an offset to memory, press the **REL**  button.

The LCD will display the **REL**  symbol and the offset will be removed from all consequent readings until the relative mode is deactivated.

To view the measured value without the offset being removed from the measurement and without losing the stored offset from memory, press the **REL Δ** button again. The LCD will display the **REL Δ** symbol flashing.

Pressing the **REL Δ** button once more will again remove the stored offset from the measurement.

To exit the relative function press the **REL Δ** button for >2 seconds. The LCD will no longer display the **REL Δ** symbol and the stored offset will be deleted from memory.

Note: Changing range or measurement function will also exit the relative function and any stored offset will be lost.

### **3.10 Min/Max**

To activate the Min/Max function, press the **MIN/MAX** button. The multimeter exits autoranging and the LCD will display **RANGE** and **MAX**.

Press **MIN/MAX** as required to alternate between displaying the maximum and minimum measured values.

Press **MIN/MAX** for >2 seconds to exit the Min/Max function.

Note: Pressing the **RANGE** button will exit the Min/Max function.

### **3.11 Display Hold**

To hold a displayed value, press the **HOLD** button. The LCD will display **HOLD**.

Press again to exit display hold.

### 3.12 High Frequency Rejection

If the AC voltage ranges are selected, there is a choice between two high frequency rejection filters.

The multimeter defaults to **HFR 2** (100kHz - 3dB point). The LCD will display the **HFR 2** symbol.

To select **HFR1** (1kHz - 3dB point), press the **HFR** button. The LCD will display the **HFR1** symbol.

Press again to return to HFR2.

### 3.13 Use of the TL16 Test Leads

Before use, always check the continuity of the test leads.

Where access to test points may require extended probe tips, the probe tip caps may be removed by gently pulling them forward until they unclip from the probe body.



### 3.14 AC Voltage Measurements

Connect the black test lead to the **COM** terminal and the red test lead to the  $\overset{\text{nsHz}\%}{\text{V } \Omega \text{ } \rightarrow}$  terminal.

Set the rotary switch to the **HFRm $\tilde{\text{V}}$**  or **HFR $\tilde{\text{V}}$**  position as required.

Set the high frequency rejection as required (see section 3.12).

Taking all necessary safety precautions connect the test leads to the circuit being measured and read the measured ac voltage from the display.

### 3.15 DC Voltage Measurements

Connect the black test lead to the COM terminal and the red test lead to the  $\overset{\text{nsHz}\%}{\text{V } \Omega \rightarrow}$  terminal.

Set the rotary switch to the  $\overline{\sim} \overline{\text{mV}}$  or  $\overline{\sim} \overline{\text{V}}$  position as required.

Taking all necessary safety precautions connect the test leads to the circuit being measured and read the measured dc voltage from the display.

### 3.16 AC+DC Voltage Measurements

Connect the black test lead to the COM terminal and the red test lead to the  $\overset{\text{nsHz}\%}{\text{V } \Omega \rightarrow}$  terminal.

Set the rotary switch to the  $\overline{\sim} \overline{\text{mV}}$  or  $\overline{\sim} \overline{\text{V}}$  position as required.

Press the **SHIFT** button. The LCD will display the  $\overset{\text{AC}}{+}$  **DC** symbol.

Taking all necessary safety precautions connect the test leads to the circuit being measured and read the measured ac+dc voltage from the display.

### 3.17 Current Measurements

Connect the black test lead to the **COM** terminal and the red test lead to the  $\mu\text{A}$  **mA**  $\leftarrow$  or **20A** terminal as required.

Set the rotary switch to the  $\mu\text{A}$   $\overline{\sim}$  or  $\overline{\sim} \overline{\text{mA}}$  position as required.

The multimeter defaults to dc current measurement. The LCD will display the **DC** symbol.

To measure ac current press the **SHIFT** button. The LCD will display the **AC** symbol.

Press **SHIFT** again to measure ac+dc current. The LCD will display the  $\overset{\text{AC}}{+}$  **DC** symbol.

Pressing **SHIFT** once more will revert back to dc current measurement.

Taking all necessary safety precautions connect the test leads to the circuit being measured and read the measured dc, ac or ac+dc current from the display.

### 3.18 Peak Hold Measurement

To record the peak+ or peak- value when making AC voltage or AC current measurements press the  $\overset{\text{PEAK } \pm}{\text{CAL} > 2\text{s}}$  button for >2 seconds.

The LCD will display **CAL** followed by **P+** and the measured peak + value.

To display the measured peak - value, press the  $\overset{\text{PEAK } \pm}{\text{CAL} > 2\text{s}}$  button. The LCD will display **P-**.

To exit the peak measurement function, press the  $\overset{\text{PEAK } \pm}{\text{CAL} > 2\text{s}}$  button for >2 seconds.

### 3.19 Resistance Measurements

Connect the black test lead to the **COM** terminal and the red test lead to the  $\overset{\text{nsHz}\%}{\text{V } \Omega \rightarrow \text{ns}}$  terminal.

Set the rotary switch to the  $\rightarrow \text{ns}$  position.

Taking all necessary safety precautions connect the test leads to the circuit being measured and read the measured resistance from the display.

### 3.20 Conductance Measurements

Connect the black test lead to the **COM** terminal and the red test lead to the  $\overset{\text{nsHz}\%}{\text{V } \Omega \rightarrow \text{ns}}$  terminal.

Set the rotary switch to the  $\rightarrow \text{ns}$  position.

Press the **SHIFT** button three times. The LCD will display the **nS** symbol.

Taking all necessary safety precautions connect the test leads to the circuit being measured and read the measured resistance from the display.

Note: Display resolution is 6000 counts only, for the conductance function.

### 3.21 Capacitance Measurements



Be sure the capacitor being tested is completely discharged before connecting the test leads.

Connect the black test lead to the **COM** terminal and the red test lead to the  **$\mu\text{A mA}$**  terminal.

Set the rotary switch to the  **$\rightarrow$**  position.

Taking all necessary safety precautions and observing the correct polarity for electrolytic capacitors, connect the test probes to the capacitor to be measured.

Read the measured capacitance from the display.

Note: Display resolution is 6000 counts only, for the capacitance function.

### 3.22 Frequency and Duty Cycle Measurements

Connect the black test lead to the **COM** terminal and the red test lead to the  **$\text{nsHz}\%$**  terminal.

Set the rotary switch to the **Hz %** position.

Taking all necessary safety precautions connect the test leads to the circuit being measured and read the measured frequency from the display.

To display the measured duty cycle press the **SHIFT** button. The LCD will display the % symbol.

Press again to revert back to measured frequency.

### 3.23 Temperature Measurements

Set the rotary switch to the °C °F position.

The multimeter defaults to measurement in °C.

For measurement in °F press the **SHIFT** button.

Press again to revert back to °C.

Connect a Type K thermocouple probe, suitable for the type of temperature measurement and temperature range being made, to the **K-TYPE** sockets.

Taking all necessary safety precautions position the thermocouple at the surface or in the medium to be measured and read the measured temperature from the display.

### 3.24 Continuity Testing

Connect the black test lead to the **COM** terminal and the red test lead to the  $\frac{nsHz\%}{V \Omega \rightarrow}$  terminal.

Set the rotary switch to the  $\frac{\rightarrow ns}{\Omega \bullet \bullet \bullet \bullet}$  position.

Press the **SHIFT** button once. The LCD will display the  $\bullet \bullet \bullet \bullet$  symbol.

Taking all necessary safety precautions connect the test leads to the circuit being tested.

If the resistance is  $<40\Omega$ , the buzzer will sound continuously. The resistance value will be displayed if  $\leq 600\Omega$ .

### 3.25 Diode Testing

If the diode to be tested is in circuit, be sure the circuit power is switched off.

Connect the black test lead to the **COM** terminal and the red test lead to the **nsHz%** terminal.

Set the rotary switch to the  **ns** position.

Press the **SHIFT** button twice. The LCD will display the  symbol.

Taking all necessary safety precautions connect the test leads to the diode being tested.

If the diode is good a forward bias will give a display reading of around 0.6V (silicon diode) and a reverse bias will give a display of **OL**. If the diode is shorted or open circuit the display will indicate approx. 0V or **OL** respectively for both forward and reverse bias.

## 4. MAINTENANCE

### 4.1 Battery Replacement



To avoid shock, injury or damage to the multimeter, disconnect it from any external circuits or components and remove the test leads before proceeding.

The battery compartment is inside the unit and can be accessed by undoing the 4 screws securing the rear casing using a Phillips head screwdriver, and removing the rear casing.

Fit a new 9V, PP3 alkaline battery (IEC 6LR61, NEDA 1604A) observing correct polarity.

Replace the rear casing and screws.

## 4.2 Fuse Replacement



To avoid shock, injury or damage to the multimeter, disconnect it from any external circuits or components and remove the test leads and battery before proceeding. Replace only with the fuses specified.

The fuses are inside the unit and can be accessed by undoing the 4 screws securing the rear casing using a Phillips head screwdriver, and removing the rear casing. Remove the protective cover from fuse F1 if required.

Replace F1 only with the original type 0.5 A/1000V 6.3x32mm fast blow ceramic fuse.

Replace F2 only with the original type 20 A/600V 10x38mm fast blow ceramic fuse.

Replace the fuse protective cover over F1, then the rear casing and screws.

## 4.3 Test Lead Replacement

If the test leads become damaged they should be replaced.



The replacement test leads must have the same (or better) overvoltage category rating as the TL16 test leads supplied.

## 4.4 Calibration

To maintain the integrity of measurements made using your instrument, Martindale Electric recommends that it is returned at least once a year to an approved Calibration Laboratory for recalibration and certification.

Martindale Electric is pleased to offer you this service. Please contact our Service Department for details.

Email: [service@martindale-electric.co.uk](mailto:service@martindale-electric.co.uk)

Tel: +44 (0)1923 650660

## 4.5 Cleaning



To reduce the risk of surface leakage, this instrument must be kept in a clean condition.



Prior to cleaning, ensure that the instrument is disconnected from any voltage source.

The unit may be cleaned using a soft dry cloth. Do not use moisture, abrasives, solvents, or detergents, which can be conductive.

## 4.6 Repair & Service

There are no user serviceable parts in this unit other than those that may be described in section 2. Return to Martindale Electric if faulty. Our service department will quote promptly to repair any fault that occurs outside the guarantee period.

Before the unit is returned, please ensure that you have checked the unit for flat batteries, blown fuses, poor connections and faulty / damaged leads.

## 4.7 Storage Conditions

The instrument should be kept in warm dry conditions away from direct sources of heat or sunlight, and in such a manner as to preserve the working life of the unit. It is strongly advised that the unit is not kept in a tool box where other tools may damage it.

## **5. WARRANTY AND LIMITATION OF LIABILITY**

This Martindale product is warranted to be free from defects in material and workmanship under normal use and service. The warranty period is 2 years and begins on the date of receipt by the end user. This warranty extends only to the original buyer or end-user customer, and does not apply to fuses, disposable batteries, test leads or to any product which, in Martindale's reasonable opinion, has been misused, altered, neglected, contaminated, or damaged by accident or abnormal conditions of operation, handling or storage.

Martindale authorised resellers shall extend this warranty on new and unused products to end-user customers only but have no authority to extend a greater or different warranty on behalf of Martindale.

Martindale's warranty obligation is limited, at Martindale's option, to refund of the purchase price, free of charge repair, or replacement of a defective product which is returned to Martindale within the warranty period.

This warranty is the buyer's sole and exclusive remedy and is in lieu of all other warranties, expressed or implied, including but not limited to any implied warranty of merchantability or fitness for a particular purpose. Martindale shall not be liable for any special, indirect, incidental or consequential damages or losses, including loss of data, arising from any cause or theory.

Since some jurisdictions do not allow limitation of the term of an implied warranty, or exclusion or limitation of incidental or consequential damages, the limitations and exclusions of this warranty may not apply to every buyer. If any part of any provision of this warranty is held invalid or unenforceable by a court or other decision-maker of competent jurisdiction, such holding will not affect the validity or enforceability of any other provision or other part of that provision.

Nothing in this statement reduces your statutory rights.

## MEASUREMENT CATEGORIES

### CAT Ratings

BS EN61010-1 Installation

Categories (CAT ratings) define the risks from hazardous transient impulses and potentially lethal short circuit currents on the mains supply system based on where you are working.

### Voltage Ratings

Test equipment used for measuring mains circuits will have a CAT rating to show where it can be used. Each category also has a voltage rating to show the maximum safe phase to earth system voltage, normally 50V, 100V, 150V, 300V, 600V or 1000V.

**Stay safe - Match your test equipment safety rating to the installation category.**

**CAT II:** Socket outlets and similar points of the mains installation.

**CAT III:** The distribution part of the building's mains installation.

**CAT IV:** The supply side source of the building's mains installation.

**Testers, leads and accessories all need safety ratings equivalent to, or higher than the installation category and voltage rating for the location to be safe.**

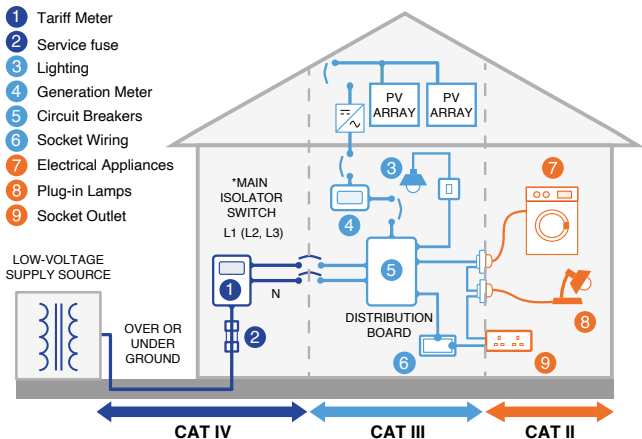



# Specification

MM94

TRMS Digital Multimeter

---



## ELECTRICAL

All specified accuracies are at 23°C ± 5°C, <70% R.H. for 1 year.

### Temperature coefficient:

0.1 x (specified accuracy) per °C. (0°C to 18°C, 28°C to 50°C).

All accuracies below are expressed as ± (percentage of reading + digits)

### DC Voltage

Range	Resolution	Input impedance	Accuracy
600mV	0.01mV	10MΩ	0.08% + 5
6V	0.0001V	11MΩ	
60V	0.001V	10MΩ	
600V	0.01V		
1000V	0.1V		

Overload protection: 1000V DC or 750V AC rms



# Specification

MM94

TRMS Digital Multimeter

## AC Voltage (True RMS)

Range	Resolution	Input impedance	Accuracy			
			HFR1 selected 45 to 60Hz	HFR2 selected		
				45Hz to 500Hz	500Hz to 1kHz	1kHz to 2kHz
600mV	0.01mV	10MΩ	2.0% + 20	1.0% + 20	1.5% + 20	N/A
6V	0.0001V	11MΩ				2.0% + 20
60V	0.001V	10MΩ				2.0% + 20
600V	0.01V			2.0% + 20	N/A	
750V	0.1V			2.0% + 20	N/A	

AC coupled true rms AC voltage accuracy is specified from 2% to 100% of range.

Crest factor: 3 at full scale, 6 at half scale

High frequency reject filter -3dB points: HFR1 at 1kHz, HFR2 at 100kHz

Peak hold accuracy (45Hz to 500Hz): 60V to 750V AC  $\pm$  (3.0% rdg + 500 dgts)

Peak hold response time: 1ms

Overload protection: 1000V DC or 750V AC rms

## AC + DC Voltage (True RMS)

Range	Resolution	Input impedance	Accuracy		
			45Hz to 500Hz	500 Hz to 1 kHz	1 kHz to 2 kHz
600mV	0.01mV	10MΩ	1.5% + 30	2.0% + 30	N/A
6V	0.0001V	11MΩ			2.5% + 30
60V	0.001V	10MΩ			2.5% + 30
600V	0.01V		2.5% + 30	N/A	
750V	0.1V		2.5% + 30	N/A	



# Specification

## MM94

### TRMS Digital Multimeter

---

AC coupled true rms AC voltage accuracy is specified from 2% to 100% of range.

Crest factor: 3 at full scale, 6 at half scale

Overload protection: 1000V DC or 750V AC rms

#### Current

Range	Resolution	Voltage burden	Accuracy		
			DC	AC (true rms)	AC+DC (true rms)
				45 Hz to 1 kHz	
600 $\mu$ A	0.01 $\mu$ A	500mV	0.5% + 10	1.5% + 20	2.0% + 30
6000 $\mu$ A	0.1 $\mu$ A	2V			
60mA	0.001mA	500mV			
400mA	0.1mA	2V	1.0% + 10	2.5% + 20	3.0% + 30
20A Note 1	1mA		2.0% + 10		

AC coupled true rms AC current accuracy is specified from 2% to 100% of range.

Crest factor: 3 at full scale, 6 at half scale

Peak hold accuracy on AC current ranges (45Hz to 500 Hz):

$$\pm (3.5\% \text{ rdg} + 500 \text{ dts})$$

Peak hold response time: 1ms

Input protection: 0.5 A/1000 V fast blow ceramic fuse on 600 $\mu$ A to 400mA ranges

20A/600V fast blow ceramic fuse on 20 A range

Note 1: Apply currents >10 A for 30 seconds maximum, then allow a 10 minute cooling period.



# Specification

MM94

TRMS Digital Multimeter

## Resistance

Range	Resolution	Open circuit voltage	Accuracy	
600 $\Omega$	0.01 $\Omega$	-3.0V dc	0.3% + 20	
6k $\Omega$	0.0001k $\Omega$	-1.2V dc		
60k $\Omega$	0.001k $\Omega$			
600k $\Omega$	0.01k $\Omega$			
6M $\Omega$	0.0001M $\Omega$			1.0% + 10
60M $\Omega$	0.001M $\Omega$			3.0% + 20

Overload protection: 600V DC or AC rms

## Conductance (6000 counts only)

Range	Resolution	Open circuit voltage	Accuracy
60nS	0.01nS	-0.7V dc	1.0% + 10

Overload protection: 600V DC or AC rms

## Capacitance (6000 counts only)

Range	Resolution	Accuracy
6nF	0.001nF	3.0% + 30
60nF	0.01nF	3.0% + 10
600nF	0.1nF	
6 $\mu$ F	0.001 $\mu$ F	
60 $\mu$ F	0.01 $\mu$ F	
600 $\mu$ F	0.1 $\mu$ F	
6mF	0.001mF	5.0% + 10

Overload Protection: 600V DC or AC rms



# Specification

MM94

TRMS Digital Multimeter

---

## Frequency

Range	Resolution	Trigger level	Accuracy
60Hz	0.001Hz	>1.5V	0.1% + 10
600Hz	0.01Hz		
6kHz	0.0001kHz		
60kHz	0.001kHz		
600kHz	0.01kHz		
6MHz	0.0001MHz	>2.5V, <5V	
10MHz	0.001MHz		

Minimum input: >6Hz

Minimum pulse width: >100 ns

Duty cycle limits: >30% and <70%

Overload protection: 600V DC or AC rms.

## Duty Cycle

Range	Resolution	Resolution	Pulse width	Accuracy (5V logic)
5% to 95%	40Hz to 1kHz	0.1%	>10 $\mu$ s	2.0% + 10
10% to 90%	1kHz to 10kHz			
20% to 80%	10kHz to 20kHz			

Overload protection: 600V DC or AC rms



# Specification

MM94

TRMS Digital Multimeter

---

## Temperature (Type K Thermocouple)

Range	Resolution	Accuracy
0°C to 400°C	0.1°C	1.0% + 1°C
-50°C to 0°C, 400°C to 1300°C		2.0% + 3°C
32°F to 750°F	0.1°F	1.0% + 2°F
-58°F to 32°F, 750°F to 2372°F		2.0% + 6°F

Overload protection: 30V DC or AC rms

## Continuity

Range	Resolution	Response time	Open circuit voltage	Audible indication
600Ω	0.01Ω	100 ms approx.	-3.0V dc	<40Ω

Overload protection: 600V DC or AC rms

## Diode Test

Range	Resolution	Test current	Open circuit voltage	Audible indication	Accuracy
2V	0.1 mV	0.5 mA typical	3.0V dc typical	<0.05V dc	2.0% + 10

Overload protection: 600 V DC or AC rms



# Specification

MM94

TRMS Digital Multimeter

---

## GENERAL

Display: Liquid crystal display

Digital, 60000 counts, updates 2/sec

Polarity: Automatic, positive implied, '-' for negative polarity indication

Overrange: (OL) or (-OL) is displayed

Bar-graph, 60 segments, updates 20/sec

Power: 9V, PP3 alkaline batteries (IEC 6LR61, NEDA 1604A)

Battery life: 50 hours typical with alkaline

Low battery indication: The LCD will display 

Auto power off: After 30 minutes

Fuses: 0.5 A/1000V 6.3x32mm fast blow ceramic fuse

20 A/600V 10x38mm fast blow ceramic fuse

Dimensions: 198 x 90 x 44mm

Weight: Approx. 400g, including battery

Includes: TL16 test leads, TT1P Type K thermocouple, 9V PP3 battery (installed), instructions

## ENVIRONMENTAL

Temperature & Humidity (Operating): 0°C to 50°C <70% R.H.

(Storage): -20°C to 60°C < 80% R.H.

Altitude: up to 2000m

Pollution degree: 2, indoor use

## SAFETY

Conforms to EN 61010-1, EN 61010-2-033, CAT IV 600V, CAT III 1000V Class II, double insulation

## EMC

Conforms to EN 61326-1



# Specification

MM94

TRMS Digital Multimeter

---

## **SPECIFICATION FOR TL16 TEST LEADS**

Maximum voltage: 1000V AC/DC

Maximum current: 10A continuous

Connector: 4mm banana plug with fixed shroud

Environmental

Temperature (Operating & Storage): 0°C to 40°C

Altitude: up to 2000m

Pollution degree: 2

## **Safety**

Conforms to EN 61010-031,

CAT IV 600V, CAT III 1000V, 10A (Probe tip caps fitted)

CAT II 1000V, 10A (Probe tip caps removed)

Class II, double insulation

## Check out what else you can get from Martindale:

- 18th Edition Testers
- Accessories
- Cable Locators
- Calibration Equipment
- Continuity Testers
- Digital Clamp Meters
- Digital Multimeters
- Electricians' Kits
- Environmental Products
- Full Calibration & Repair Service
- Fuse Finders
- Labels
- Microwave Leakage Detectors
- Multifunction Testers
- PAT Testers & Accessories
- Phase Rotation Testers
- Proving Units
- Safe Isolation Kits
- Socket Testers
- Specialist Drummond Testers
- Thermometers & Probes
- Test Leads
- Voltage Indicators

Martindale Electric Co. Ltd. Metrohm House,  
12 Imperial Park, Imperial Way, Watford WD24 4PP, UK.

T: +44 (0)1923 441717

[www.martindale-electric.co.uk](http://www.martindale-electric.co.uk) [sales@martindale-electric.co.uk](mailto:sales@martindale-electric.co.uk)

### Ver. F1.0

Due to policy of continuous development, Martindale Electric reserves the right to alter equipment specification and description outlined in this document without prior notice. No part of this document shall be deemed to be part of any contract for the equipment unless specifically referred to as an inclusion within such contract. © 2026 Martindale Electric Co. Ltd. Registered in England No. 3387451. LITMM94