

CM79 TRMS AC/DC CLAMP METER

INSTRUCTION MANUAL



MARTINDALE
● ● ● ELECTRIC

Keeping You Safe



ALWAYS READ THESE INSTRUCTIONS BEFORE PROCEEDING

Thank you for buying one of our products. For safety and a full understanding of its benefits please read this manual before use. Technical support is available from 01923 441717 and support@martindale-electric.co.uk

CONTENTS

1	Safety Information	1
1.1	Meaning of Symbols and Markings	1
1.2	Precautions	2
2	Introduction	5
2.1	Inspection	5
2.2	Description	5
2.3	Accessories	5
2.4	Battery Installation	5
3	Operation	6
3.1	General	6
3.2	Low Battery Indication	6
3.3	Description of Clamp Meter Elements	6
3.4	Description of Press Buttons	7
3.5	Description of LCD Symbols	7
3.6	Auto Power Off	7
3.7	Backlight	8
3.8	Display Hold	8
3.9	Zero Function	8
3.10	Min/Max Function	8
3.11	Use of the TL16 Test Leads	9
3.12	AC Current Measurements	9
3.13	DC Current Measurements	10
3.14	AC Voltage Measurements	10
3.15	DC Voltage Measurements	10
3.16	Resistance Measurements and Continuity Testing	11
4	Maintenance	12
4.1	Battery Replacement	12
4.2	Test Lead Replacement	12
4.3	Calibration	13
4.4	Cleaning	13
4.5	Repair & Service	13
4.6	Storage Conditions	14
5	Warranty	15
	Measurement Categories	17
	Specifications	

1. SAFETY INFORMATION: Always read before proceeding.

REMEMBER: SAFETY IS NO ACCIDENT

These instructions contain both information and warnings that are necessary for the safe operation and maintenance of this product. It is recommended that you read the instructions carefully and ensure that the contents are fully understood. Failure to understand and to comply with the warnings and instructions can result in serious injury, damage or even death.

Particular attention should be paid to the Warnings, Precautions and Technical Specifications.

Please keep these instructions for future reference. Updated instructions and product information are available at: www.martindale-electric.co.uk

1.1 Meaning of Symbols and Markings



Caution - risk of danger & refer to instructions



Caution - risk of electric shock



Equipment protected by double or reinforced insulation (Class II)



Application around and removal from hazardous live conductors is permitted.

CAT II (Measurement Category II) is applicable to test and measuring equipment connected directly to utilization points (socket outlets and similar points) of the low-voltage MAINS installation.

CAT III (Measurement Category III) is applicable to test and measuring equipment connected to the distribution part of the building's low-voltage MAINS installation.

CAT IV (Measurement Category IV) is applicable to test and measuring equipment connected at the source of the building's low-voltage MAINS installation.

For further information on measurement categories see page 17 or visit www.martindale-electric.co.uk/measurement_categories.php



Equipment complies with relevant EU Directives



End of life disposal of this equipment should be in accordance with relevant EU Directives

1.2 Precautions

This product has been designed with your safety in mind, but please pay attention to the following warnings and cautions before use.



Warnings

In order to avoid the danger of electrical shock, it is important that proper safety measures are taken when working with voltages exceeding 30V AC rms, 42V AC peak or 60V DC.

Where applicable other safety measures such as the use of protective gloves, goggles etc. should be employed.

The clamp meter must only be used by a skilled and competent person who is familiar with the relevant regulations, the safety risks involved and the consequent normal safe working practices, and under the conditions and for the purposes for which it has been constructed and specified.

Before each use the clamp meter and any associated test leads and accessories should be examined for damage, cracks, cuts or scratches. **Do not use if damaged in any way.**

Make sure the clamp meter and test leads are dry, clean and free from dust, grease and moisture while in use to avoid the danger from electric shock due to surface leakage.

Always test this unit on an appropriate proving device or a known good voltage source before and after using it to determine if a hazardous voltage exists in a circuit to be tested. **Do not use** the unit if it does not function correctly during proving.

Measuring/testing for a voltage/current that exceeds the specified limits of the unit may damage the unit and may expose the operator to a shock hazard. Always check the unit's specified limits before use.

As a clamp meter or multimeter the unit must only be used on CAT III and CAT II installations up to 600V to earth, and within the operating temperature and humidity range specified.

If the removable probe tip caps are not fitted to the probes of the test leads, their measurement category becomes CAT II 1000V, and they **must not be used** on CAT III or CAT IV installations to avoid the risk of shorting high energy circuits and arc flash.

When this unit is used in combination with test leads, the measurement category of the combination is the lower measurement category of either this unit or the test leads used. Likewise if test lead accessories such as crocodile clips are also used, the measurement category will be the lowest measurement category in that combination.

Do not use if the battery compartment cover is not fitted.
When using test leads, **always** keep your fingers behind the finger guard on the test lead probe.

When positioning the clamp jaws around a hazardous live conductor **always** keep your fingers behind the clamp safety protection barrier.

When making current measurements using the clamps, disconnect the test leads from the clamp meter terminals.

Cautions

Avoid severe mechanical shock or vibration and extreme temperature.

When using test leads avoid excessive stresses to the cable entry points at the probe and 4mm plug connector.

To avoid possible corrosion from leaking batteries, remove the batteries when the unit is not in use for an extended period.

2. INTRODUCTION

2.1 Inspection

Examine the shipping carton for any sign of damage. Inspect the unit and any accessories for damage. If there is any damage then consult your distributor immediately.

2.2 Description

The Martindale CM79 has the following measurement functions:

- ◆ True RMS AC current to 600A
- ◆ DC current to 600A
- ◆ True RMS AC voltage to 600V
- ◆ DC voltage to 600V
- ◆ Resistance to 1000 Ω
- ◆ Continuity with audible indication

Further functions are:

- ◆ Display hold
- ◆ Min/Max indication
- ◆ Auto power off
- ◆ Display backlight

2.3 Accessories

The CM79 comes with the following accessories:

- ◆ Carrying case
- ◆ Set of TL16 test leads
- ◆ 2 x 1.5V AAA batteries
- ◆ Instructions

2.4 Battery Installation

Refer to section 4.1 (Battery Replacement) for the battery installation instructions.

3. OPERATION

3.1 General

If the insulation clamp meter displays **OL** then the measurement limits of the range have been exceeded.

3.2 Low Battery Indication

If the  symbol is displayed, the battery needs replacing as measurement accuracy can no longer be guaranteed (see section 4.1 Battery Replacement).

3.3 Description of Clamp Meter Elements

1	Clamp current sensing jaws
2	Clamp safety protection barrier
3	Clamp trigger
4	Rotary function selector switch
5	Min/Max and Zero button
6	Backlight button
7	Hold button
8	Liquid crystal display
9	COM input terminal
10	Positive input terminal
11	Positive input terminal

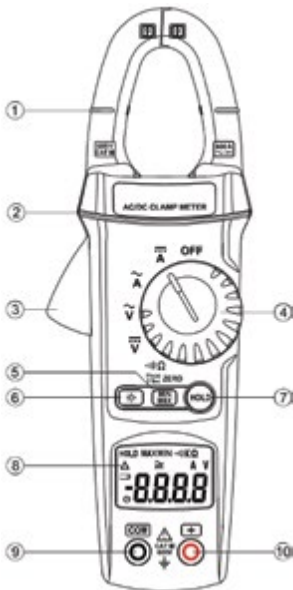











Figure 1

3.4 Description of Press Buttons

	Selects backlight
	Selects minimum/maximum function Zero's display offsets
	Selects hold function

3.5 Description of LCD Symbols





HOLD	Display hold is activated
MAX	The maximum reading is being displayed
MIN	The minimum reading is being displayed
	Continuity function is selected
A, V, Ω,	Units of measurement being displayed
	Zeroing is activated
	Indicates AC measurement
	Indicates DC measurement
	Indicates low battery
	Auto power off is activated

3.6 Auto Power Off

If the clamp meter is inactive for a period of 30 minutes it will automatically power off.

If any button is pressed after the clamp meter has automatically powered off, the clamp meter will turn back on.

To disable the auto power off function, press  at the same time as turning the rotary switch from **OFF** to any position. When the meter beeps, release . The  symbol will no longer be displayed on the LCD.

3.7 Backlight

Press  to turn on the backlight. Press again to turn the backlight off.



The backlight will automatically turn off after 30 seconds to conserve the battery.

3.8 Display Hold

To hold a displayed value, press . The LCD will display **HOLD**.

Press again to exit display hold.

3.9 Zero Function

Press  for 2 seconds to remove a displayed offset. The LCD will display .

Press again for 2 seconds to exit the zero function.

3.10 Min/Max Function

To display the maximum measured value press . The LCD will display **MAX**.

To display the minimum measured value press . The LCD will display **MIN**.

Pressing  for a third time will return the meter to a normal display mode with maximum and minimum measured values being stored. The LCD will display **MAX MIN** flashing.

To exit the Min/Max function, press **MIN MAX** for 2 seconds.

3.11 Use of the TL16 Test Leads

Before use, always check the continuity of the test leads.

Where access to test points may require extended probe tips, the probe tip caps may be removed by gently pulling them forward until they unclip from the probe body.



3.12 AC Current Measurements

Set the rotary switch to the **\tilde{A}** position.

Taking all necessary safety precautions, press the clamp meter trigger to open the clamp jaws, position the jaws around the conductor to be measured, and release the trigger to close the jaws.

Position the clamp meter so the conductor is central within the clamp jaws.

Read the measured ac current from the display.

Note. Clamping around more than one conductor will result in an incorrect measurement.

3.13 DC Current Measurements

Set the rotary switch to the \overline{A} position.

Taking all necessary safety precautions, press the clamp meter trigger to open the clamp jaws, position the jaws around the conductor to be measured, and release the trigger to close the jaws.

Position the clamp meter so the conductor is central within the clamp jaws.

Read the measured dc current from the display.

Note. Clamping around more than one conductor will result in an incorrect measurement.

3.14 AC Voltage Measurements

Connect the black test lead to the \boxed{COM} terminal and the red test lead to the $\boxed{\oplus}$ terminal.

Set the rotary switch to the \tilde{V} position.

Taking all necessary safety precautions connect the test leads to the circuit being measured.

Read the measured ac voltage from the display.

3.15 DC Voltage Measurements

Connect the black test lead to the \boxed{COM} terminal and the red test lead to the $\boxed{\oplus}$ terminal.

Set the rotary switch to the \overline{V} position.

Taking all necessary safety precautions connect the test leads to the circuit being measured.

Read the measured dc voltage from the display.

3.16 Resistance Measurements and Continuity Testing

Connect the black test lead to the **COM** terminal and the red test lead to the **+** terminal.

Set the rotary switch to the **Ω** position.

Taking all necessary safety precautions connect the test leads to the circuit being measured or tested.

Read the measured resistance from the display.

If the resistance is $\leq 40\Omega$, the buzzer will sound continuously.

4. MAINTENANCE

4.1 Battery Replacement



To avoid shock or injury, disconnect the clamp meter from any external circuits and remove the test leads before proceeding.

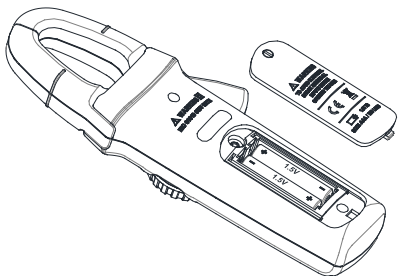

Figure 2

Referring to figure 2, the battery compartment is underneath the unit and can be accessed by removing the screw and lifting off the cover.

Fit 2 new 1.5V, AAA alkaline batteries (IEC LR03, NEDA 24A) observing correct polarity.

Replace the battery compartment cover and screw.

Note: Do not mix old and new batteries.

4.2 Test Lead Replacement

If the test leads become damaged they should be replaced.



The replacement test leads must have the same (or better) overvoltage category rating as the TL16 test leads supplied.

4.3 Calibration

To maintain the integrity of measurements made using your instrument, Martindale Electric recommends that it is returned at least once a year to an approved Calibration Laboratory for recalibration and certification.

Martindale Electric is pleased to offer you this service.

Please contact our Service Department for details.

Email: service@martindale-electric.co.uk

Tel: 01923 650660

4.4 Cleaning



To reduce the risk of surface leakage, this instrument must be kept in a clean condition.

Prior to cleaning, ensure that the instrument is disconnected from any voltage source.

If contamination is found, clean with a damp soft cloth and if necessary a mild detergent or alcohol. Do not use abrasives, abrasive solvents, or detergents which can cause damage to the unit. If a mild detergent is used, the unit should subsequently be thoroughly cleaned with a water dampened soft cloth. After cleaning, dry and allow to remain in a dry environment for 2 hours before use.

4.5 Repair & Service

There are no user serviceable parts in this unit other than those that may be described in section 4. Return to Martindale Electric if faulty. Our service department will quote promptly to repair any fault that occurs outside the guarantee period.

Before the unit is returned, please ensure that you have checked the unit, batteries, leads and for poor connections.

4.6 Storage Conditions

The instrument should be kept in warm dry conditions away from direct sources of heat or sunlight, and in such a manner as to preserve the working life of the unit. It is strongly advised that the unit is not kept in a tool box where other tools may damage it.

5. WARRANTY AND LIMITATION OF LIABILITY

This Martindale product is warranted to be free from defects in material and workmanship under normal use and service. The warranty period is 2 years and begins on the date of receipt by the end user. This warranty extends only to the original buyer or end-user customer, and does not apply to fuses, disposable batteries, test leads or to any product which, in Martindale's reasonable opinion, has been misused, altered, neglected, contaminated, or damaged by accident or abnormal conditions of operation, handling or storage.

Martindale authorised resellers shall extend this warranty on new and unused products to end-user customers only but have no authority to extend a greater or different warranty on behalf of Martindale. Martindale's warranty obligation is limited, at Martindale's option, to refund of the purchase price, free of charge repair, or replacement of a defective product which is returned to Martindale within the warranty period.

This warranty is the buyer's sole and exclusive remedy and is in lieu of all other warranties, expressed or implied, including but not limited to any implied warranty of merchantability or fitness for a particular purpose. Martindale shall not be liable for any special, indirect, incidental or consequential damages or losses, including loss of data, arising from any cause or theory.

Since some jurisdictions do not allow limitation of the term of an implied warranty, or exclusion or limitation of incidental or consequential damages, the limitations and exclusions of this warranty may not apply to every buyer. If any part of any provision

of this warranty is held invalid or unenforceable by a court or other decision-maker of competent jurisdiction, such holding will not affect the validity or enforceability of any other provision or other part of that provision.

Nothing in this statement reduces your statutory rights.

MEASUREMENT CATEGORIES

CAT Ratings

BS EN61010-1 Installation

Categories (CAT ratings) define the risks from hazardous transient impulses and potentially lethal short circuit currents on the mains supply system based on where you are working.

Voltage Ratings

Test equipment used for measuring mains circuits will have a CAT rating to show where it can be used. Each category also has a voltage rating to show the maximum safe phase to earth system voltage, normally 50V, 100V, 150V, 300V, 600V or 1000V.

Stay safe - Match your test equipment safety rating to the installation category.

CAT II: Socket outlets and similar points of the mains installation.

CAT III: The distribution part of the building's mains installation.

CAT IV: The supply side source of the building's mains installation.

Testers, leads and accessories all need safety ratings equivalent to, or higher than the installation category and voltage rating for the location to be safe.

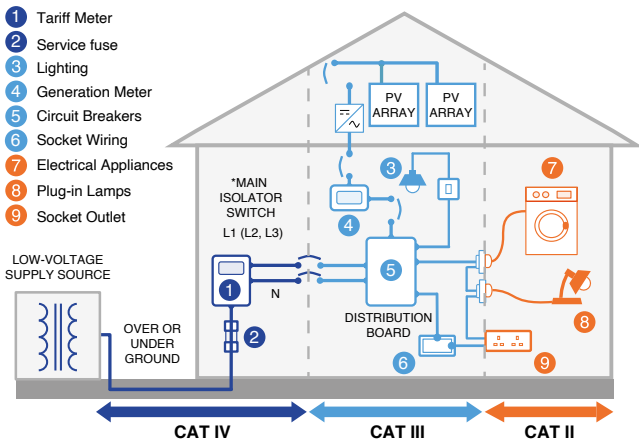

**ELECTRICAL**

All specified accuracies are at 23°C ± 5°C, <80% RH for 1 year.

Temperature coefficient: Add 0.1 x (specified accuracy) per °C. (0°C to 18°C, 28°C to 40°C).

Accuracies below are expressed as ± (percentage of reading + digits)

DC Voltage

Range	Resolution	Input impedance	Accuracy
600V	0.1V	1MΩ	1.0% + 2

Overload protection: 660V DC or AC rms

AC Voltage (True RMS)

Range	Resolution	Input impedance	Accuracy (50 to 500Hz)
600V	0.1 V	1MΩ	1.2% + 5

Overload protection: 660V DC or AC rms



Specification

CM79

TRMS AC/DC Clamp Meter

DC Current

Range	Resolution	Accuracy
60A	0.01A	2.0% + 5
600A	0.1A	

Overload protection: 660A DC or AC rms

AC Current (True RMS)

Range	Resolution	Accuracy	
		(50 to 60Hz)	(60 to 500Hz)
60A	0.01A	2.0% + 5	3.0% + 5
600A	0.1A		

Overload protection: 660A DC or AC rms

Resistance

Range	Resolution	Open circuit voltage	Accuracy
1000 Ω	0.1 Ω	3V dc	1.0% + 2

Overload protection: 600V DC or AC rms

Continuity

Open circuit voltage	Audible indication
3V dc	$\leq 40\Omega$

Overload protection: 600V DC or AC rms

GENERAL

Display: Liquid crystal display with maximum reading 6200

Sample rate: 3 times/sec

Polarity: automatic, positive implied, '-' for negative polarity indication

Overrange: (OL) is displayed

Power: 2 x 1.5V, AAA alkaline batteries (IEC LR03, NEDA 24A)

Battery life (alkaline): 50 hours typical (without buzzer function or backlight)

Low battery indication:  symbol is displayed

Auto power off: after 30 minutes

Jaw opening capability: 25mm

Dimensions: 210 x 62 x 36mm

Weight: 273g approx. Including batteries

Includes: carrying case, set of TL16 test leads, 2 x 1.5V AAA batteries, instructions

ENVIRONMENTAL

Temperature & Humidity:

(Operating): 0°C to 40°C <80% R.H., non-condensing

(Storage): -10°C to 60°C <70% R.H., batteries removed

Altitude: up to 2000m

Pollution degree: 2

SAFETY

Conforms to: BS EN 61010-1, BS EN 61010-2-032, CAT III 600V, CAT IV 300V
Class II, double insulation

EMC

Conforms to BS EN 61326-1



Keeping You Safe

Specification

CM79

TRMS AC/DC Clamp Meter

SPECIFICATION FOR TL16 TEST LEADS

Maximum voltage: 1000V AC/DC

Maximum current: 10A continuous

Connector: 4mm banana plug with fixed shroud

Environmental

Temperature (Operating & Storage): 0°C to 40°C

Altitude: up to 2000m

Pollution degree 2

Safety

Conforms to BS EN 61010-031, CAT IV 600V, CAT III 1000V, 10A (probe tip covers fitted)

CAT II 1000V, 10A (probe tip covers removed)

Class II, double insulation

Check out what else you can get from Martindale:

- 18th Edition Testers
- Accessories
- Cable Locators
- Calibration Equipment
- Continuity Testers
- Digital Clamp Meters
- Digital Multimeters
- Electricians' Kits
- Environmental Products
- Full Calibration & Repair Service
- Fuse Finders
- Labels
- Microwave Leakage Detectors
- Multifunction Testers
- PAT Testers & Accessories
- Phase Rotation Testers
- Proving Units
- Safe Isolation Kits
- Socket Testers
- Specialist Drummond Testers
- Thermometers & Probes
- Test Leads
- Voltage Indicators

Martindale Electric Co. Ltd. Metrohm House, 12 Imperial Park, Imperial Way, Watford WD24 4PP. T: +44 (0)1923 441717
www.martindale-electric.co.uk sales@martindale-electric.co.uk

Ver. D1.0

Due to policy of continuous development, Martindale Electric reserves the right to alter equipment specification and description outlined in this document without prior notice. No part of this document shall be deemed to be part of any contract for the equipment unless specifically referred to as an inclusion within such contract. © 2026 Martindale Electric Co. Ltd. Registered in England No. 3387451. LITCM79