

# IRC327 ADVANCED THERMAL CAMERA

## INSTRUCTION MANUAL



### **⚠ ALWAYS READ THESE INSTRUCTIONS BEFORE PROCEEDING**

Thank you for buying one of our products. For safety and a full understanding of its benefits please read this manual before use. Technical support is available from 01923 441717 and support@martindale-electric.co.uk.

#### CONTENTS

<b>1</b>	<b>Safety Information</b>	<b>1</b>
1.1	Meaning of Symbols and Markings	1
1.2	Precautions	2
<b>2</b>	<b>Introduction</b>	<b>4</b>
2.1	Inspection	4
2.2	Description	4
2.3	Accessories	4
2.4	Battery Installation	4
<b>3</b>	<b>Operation</b>	<b>5</b>
3.1	Low Battery Indication	5
3.2	IRC327 Elements	5
3.3	Description of Display	6
3.4	Power On/Off	6
3.5	Menu Navigation	7
3.6	Menu Functions	7
	Viewing Saved SD Card Images	8
	Colour Palette Setting	8
	Emissivity Setting	8
	Laser Crosshair	9
	Temperature Scale Setting	9
	Flash/UV Function Setting	9
	Screen Crosshair Setting	9
	Auto Power Off Timer Setting	9
	Time and Date Setting	9
	Information	9
3.7	Measurement, Scanning and Saving Images	10
3.8	Measurement Considerations	10
3.9	Emissivity (EMS) Values	11

3.10	Transferring Saved Images to a PC or Laptop	12
3.11	UV Leak Detection	13
<b>4</b>	<b>Maintenance</b>	<b>14</b>
4.1	Battery Replacement	14
4.2	Calibration	14
4.3	Cleaning	14
4.4	Repair & Service	15
4.5	Storage Conditions	15
<b>5</b>	<b>Warranty</b>	<b>16</b>
	<b>Specifications</b>	

### 1. SAFETY INFORMATION

#### **⚠ REMEMBER: SAFETY IS NO ACCIDENT**

These instructions contain both information and cautions that are necessary for the correct operation and maintenance of this product. It is recommended that you read the instructions carefully and ensure that the contents are fully understood.

Particular attention should be paid to the Precautions and Technical Specifications.

Please keep these instructions for future reference. Updated instructions and product information are available at: [www.martindale-electric.co.uk](http://www.martindale-electric.co.uk)

#### 1.1 Meaning of Symbols and Markings



**Caution - refer to instructions**



**Caution - Laser radiation**

**Class 2 Laser** Class 2 lasers are limited to a maximum output power of 1 milliwatt or one-thousandth of a watt (abbreviated to mW) and the beam must have a wavelength between 400 and 700 nm. A person receiving an eye exposure from a Class 2 laser beam, either accidentally or as a result of someone else's deliberate action (misuse) will be protected from injury by their own natural aversion response. This is a natural involuntary response which causes the individual to blink and avert their head thereby terminating the eye exposure. Repeated, deliberate

exposure to the laser beam may not be safe. Some laser pointers and barcode scanners are Class 2 laser products.

**CE** Equipment complies with relevant EU Directives

**End of life disposal of this equipment should be in accordance with relevant EU Directives.**

### 1.2 Precautions

This product has been designed with your safety in mind, but please pay attention to the following warnings and cautions before use.

#### **Warnings**

The IRC325 and IRC327 must only be used by a skilled and competent person who is familiar with the relevant regulations, the safety risks involved and the consequent normal safe working practices, and under the conditions and for the purposes for which it has been constructed and specified.

**Do not** use if damaged.

**Never** look or stare into the laser beam as permanent eye damage could result.

**Never** direct the laser beam at any person's (or animal's) eyes as eye damage could result.

Reflections of the laser beam from mirrors or other shiny surfaces can be as hazardous as direct eye exposure.

Objects may be much hotter than indicated due to factors such as emissivity.

2

#### **⚠ Cautions**

Avoid severe mechanical shock or vibration and extreme temperature.

To avoid possible corrosion from leaking batteries, remove the batteries if discharged, or when the unit is not in use for an extended period.

3

## 2. INTRODUCTION

### 2.1 Inspection

Examine the shipping carton for any sign of damage. Inspect the unit and any accessories for damage. If there is any damage then consult your distributor immediately.

### 2.2 Description

The Martindale IRC327 has the following functions and features:

- ◆ Easy to use single button image capture
- ◆ 4.5 cm colour TFT display
- ◆ Blended image for fast troubleshooting
- ◆ Temperature range -30°C to 650°C (-22°F to 1202°F)
- ◆ Laser pointer for easy targeting
- ◆ Adjustable emissivity
- ◆ 3 selectable colour palettes
- ◆ UV light for leak detection
- ◆ Built-in 5 LED torch
- ◆ SD card memory for image storage and download
- ◆ Micro-USB port
- ◆ Adjustable auto power off timer

### 2.3 Accessories

The IRC327 come with the following accessories:

- ◆ 3 x 1.5V AA alkaline batteries
- ◆ 2 GB micro SD card
- ◆ Instructions

### 2.4 Battery Installation

Refer to Section 4.1 (Battery Replacement) for battery installation instructions.

4

## 3. OPERATION

### 3.1 Low Battery Indication

If the  symbol is displayed, the battery needs replacing as measurement accuracy can no longer be guaranteed (See section 4.1 Battery Replacement).

### 3.2 IRC327 Elements

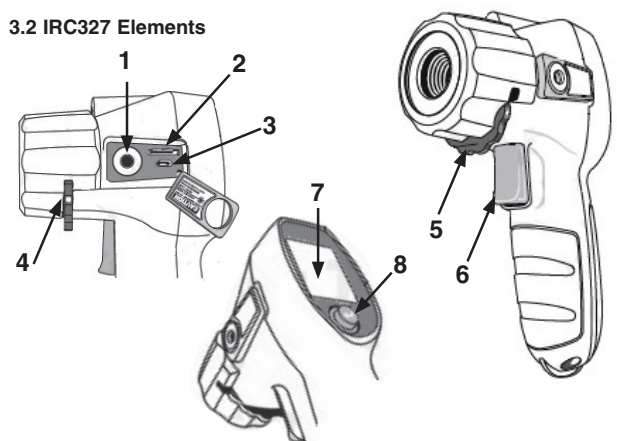

1	Tripod mounting point
2	Micro SD card
3	Micro USB port
4	Green dot
5	Thumbwheel ON/OFF switch and lens cover
6	Trigger
7	Display
8	Toggle switch

5

### 3.3 Description of Display

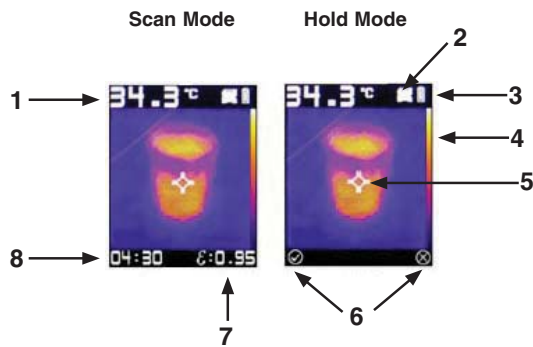

1	Measured temperature at crosshair
2	Indicates micro-SD card is installed
3	Battery level indication
4	The narrow stripe down the left side indicates the palette setting
5	Screen crosshair
6	Indicates toggle right to save image, toggle left to discard
7	Emissivity value setting
8	Time

### 3.4 Power On/Off

To power on, turn the thumbwheel until the green dot is visible on the edge of the thumbwheel and it clicks into the ON position.

The screen will display MARTINDALE ELECTRIC for approx. 10 seconds as the unit warms up.

6

To power off, turn the thumbwheel until it clicks into the OFF position.

**Note:** If the thumbwheel is not in the click position, the unit will be powered on, but the lens cover may partially obscure the thermal imaging detector and laser.

### 3.5 Menu Navigation

The toggle switch is used to navigate and edit the menu functions.

Toggle **LEFT** to select the **MENU**.

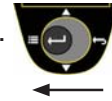

Toggle **UP** or **DOWN** to scroll through the menu **FUNCTIONS** and **SUB-MENU'S**.



Press the switch **IN** to **SELECT** or **DESELECT** the menu and sub-menu choices.



Toggle **RIGHT** to **EXIT** the menu and sub-menu's.



In the menu and sub-menus: ■ indicates selected.

■ indicates deselected.

### 3.6 Menu Functions

Refer to section 3.5 for guidance on menu navigation and selecting and setting up the functions.

7

### Viewing Saved SD Card Images

In the menu select the  icon to display the first saved image. Toggle through all other saved images.

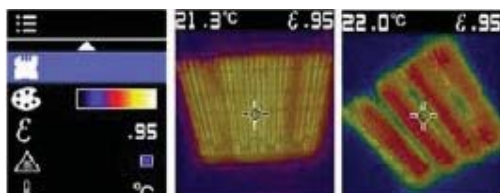

### Colour Palette Setting

In the menu select the  icon.

There are three selectable palettes, **Greyscale**, **Hot Iron** and **Rainbow**.

The **greyscale**  palette is useful for identifying detail on an image.

The **hot iron**  palette covers a useful range of hot/cold colour differentials.

The **rainbow**  palette has the best thermal sensitivity for displaying temperature difference.

### Emissivity Setting

To obtain the best temperature measurements the emissivity value should be set to suit the type of surface being measured. See section 3.9.

In the menu select the  icon.

8

Fixed values of **0.95**, **0.80**, **0.60** and **0.30** can be selected or any value between **0.10** and **0.99** can be set by selecting the variable function.

### Laser Crosshair

The laser crosshair can be turned ON or OFF. In the menu select the  icon.

### Temperature Scale Setting

The temperature scale can be set to °C or °F. In the menu select the  icon.

### Flash/UV Function Settings

The flash and UV source can be set to **OFF**, **FLASH** only, **UV** only and **UV+FLASH**.

In the menu select the  icon.

### Screen Crosshair Setting

If required, the screen crosshair can be turned off so it does not appear in saved images.

In the menu select the  icon.

### Auto Power Off Timer Setting

The auto power off timer can be set to **OFF**, **1**, **2**, **5** or **10** minutes. In the menu select the  icon.

### Time and Date Setting

The time and date can be set. In the menu select the  icon.

### Information

Selecting  in the menu will display the current firmware version.

9

### 3.7 Measurement, Scanning and Saving Images

Power ON the IRC327 and referring to sections 3.6 and 3.8 set up the IRC327 functions as required.

Point the IRC327 at the object of interest and press the trigger to activate the LASER/FLASH/UV source if enabled.

Move the IRC327 until the screen centre/screen crosshair/laser crosshair is aligned with the area of interest.

The temperature at the screen centre/screen crosshair/laser crosshair centre will be displayed.

Releasing the trigger will hold the image and the displayed temperature.

To save the displayed image to the micro-SD card toggle RIGHT, to discard toggle LEFT.

The screen will automatically revert to scan mode after 4 seconds.

### 3.8 Measurement Considerations

- ◆ The surface emissivity setting of the target surface must be taken into account when measuring temperature. See section 3.8 for typical surface emissivity values of various materials. Set the correct emissivity value as described in section 3.6.
- ◆ The distance to spot ratio of the IRC327 is 30:1. At a distance of 30 feet the spot diameter would be 1 foot and is represented by the outer circle of the laser crosshair. The measured temperature is the average temperature within the area of the outer circle of the laser crosshair. For accurate temperature measurement the laser crosshair outer circle must be within the target area. See figure 1.

10

Figure 1

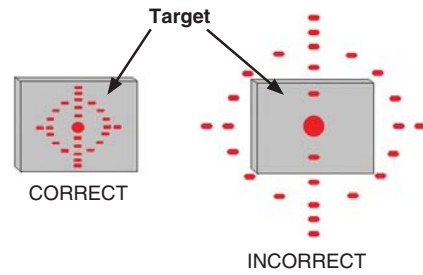

- ◆ Allow time before use for temperature stabilisation if the IRC327 is moved between locations with differing ambient temperatures, e.g. one location at 23°C and another at 0°C. Up to 30 minutes may be required for extreme temperature changes.
- ◆ Reflected background temperature can effect temperature measurement. Very hot objects or very cold objects in the vicinity of the target or object of interest can affect the apparent temperature and measurement accuracy, especially when surface emissivity is low.

### 3.9 Emissivity Values

The emissivity of the surface of a material is its effectiveness in emitting energy as thermal radiation. Quantitatively, emissivity is the ratio of the thermal radiation from a surface to the radiation from an ideal black body surface at the same temperature as given by the Stefan–Boltzmann law.

Refer to table 1 for the nominal surface emissivity values for various materials.

11

Table 1

Material	Value	Material	Value
Aluminium *	0.30	Leather ***	0.78
Asbestos	0.95	Lead *	0.50
Asphalt	0.95	Oil	0.94
Brass *	0.50	Paint	0.93
Ceramic	0.95	Plastic **	0.95
Concrete	0.95	Rubber	0.95
Copper *	0.60	Sand	0.90
Food-frozen	0.90	Steel *	0.80
Food-hot	0.93	Snow	0.83
Glass (plate)	0.85	Skin (human)	0.98
Iron *	0.70	Water	0.93
Ice	0.97	Wood ***	0.94

\* Oxidized    \*\* Opaque, over 20 mils    \*\*\* Natural

### 3.10 Transferring Saved Images to a PC or Laptop

The images saved to the SD card can be transferred to a PC or laptop in one of two ways:

By removing the SD card and connecting it to the PC or laptop using a suitable adaptor;

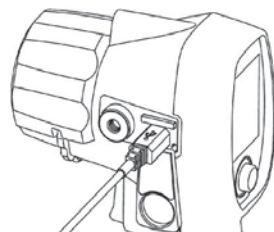

By connecting the IRC327 directly to a PC or laptop using a micro-USB to USB cable (preferred method).

The SD card and micro-USB port can be accessed by removing the rubber cover with the laser warning from around the tripod mounting point.

12

To remove the SD card press it in against the spring pressure and it will pop out.

A micro-SD card of 2 GB is supplied, but a card up to 32 GB may be used.

If connecting to a PC or laptop with a USB cable the IRC327 must be switched OFF.

The IRC327 will be recognised as a USB device and the images can be transferred, erased, etc. in the normal way.

The images are saved in bitmap (.BMP) format and include the measured temperature reading and emissivity setting information.

### 3.11 UV Leak Detection

The IRC327 can be used for leak detection in cooling systems, air conditioning systems, etc. by using a suitable UV indicator dye.

To enable the UV function, see sections 3.5 and 3.6.

13

## 4. MAINTENANCE

### 4.1 Battery Replacement

The battery compartment is in the handle of the unit.

Remove the battery cover screw and the battery cover.

Replace with 3 new 1.5V, AA alkaline batteries (IEC LR6, NEDA 15A), observing correct polarity.

Replace the battery cover and screw.

**Note:** Do not mix old and new batteries.

### 4.2 Calibration

To maintain the integrity of measurements made using your instrument, Martindale Electric recommends that it is returned at least once a year to an approved Calibration Laboratory for recalibration and certification.

Martindale Electric is pleased to offer you this service. Please contact our Service Department for details.

Email: [service@martindale-electric.co.uk](mailto:service@martindale-electric.co.uk)

Tel: 01923 650660

### 4.3 Cleaning

If contamination is found, clean with a damp soft cloth and if necessary a mild detergent or alcohol. If required use a cotton bud to clean the lens. Do not use abrasives, abrasive solvents, or detergents which can cause damage to the unit. If a mild detergent is used, the unit should subsequently be thoroughly cleaned with a water dampened soft cloth. After cleaning, dry and allow to remain in a dry environment for 2 hours before use.

14

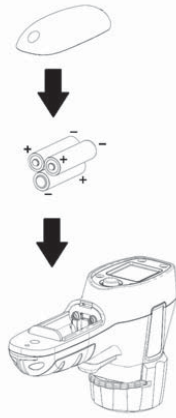

### 4.4 Repair & Service

There are no user serviceable parts in this unit other than those that may be described in section 4. Return to Martindale Electric if faulty. Our service department will quote promptly to repair any fault that occurs outside the guarantee period.

Before the unit is returned, please ensure that you have checked the unit and batteries.

### 4.5 Storage Conditions

The instrument should be kept in warm dry conditions away from direct sources of heat or sunlight, and in such a manner as to preserve the working life of the unit. It is strongly advised that the unit is not kept in a tool box where other tools may damage it.

15

## 5. WARRANTY AND LIMITATION OF LIABILITY

This Martindale product is warranted to be free from defects in material and workmanship under normal use and service. The warranty period is 2 years and begins on the date of receipt by the end user. This warranty extends only to the original buyer or end-user customer, and does not apply to fuses, disposable batteries, test leads or to any product which, in Martindale's opinion, has been misused, altered, neglected, contaminated, or damaged by accident or abnormal conditions of operation, handling or storage.

Martindale authorised resellers shall extend this warranty on new and unused products to end-user customers only but have no authority to extend a greater or different warranty on behalf of Martindale.

Martindale's warranty obligation is limited, at Martindale's option, to refund of the purchase price, free of charge repair, or replacement of a defective product which is returned to Martindale within the warranty period.

This warranty is the buyer's sole and exclusive remedy and is in lieu of all other warranties, expressed or implied, including but not limited to any implied warranty of merchantability or fitness for a particular purpose. Martindale shall not be liable for any special, indirect, incidental or consequential damages or losses, including loss of data, arising from any cause or theory.

Since some jurisdictions do not allow limitation of the term of an implied warranty, or exclusion or limitation of incidental or consequential damages, the limitations and exclusions of this warranty may not apply to every buyer. If any part of any provision of this warranty is held invalid or unenforceable by a court or other decision-maker of competent jurisdiction, such holding will not affect the validity or enforceability of any other provision or other part of that provision.

Nothing in this statement reduces your statutory rights.

16



## Specification IRC327 Advanced Thermal Camera



### TEMPERATURE

Temperature range: -30°C to 650°C  
(-22°F to 1202°F)

Temperature resolution: 0.1°C (0.2°F)

Temperature accuracy:

Temperature	Accuracy *
≥0°C	±1.5°C or ±1.5% of reading (whichever is greater)
≥32°F	±3°F or ±1.5% of reading (whichever is greater)
≥-10°C to <0°C	±2°C
≥14°C to <32°C	±4°F
<-10°C	±3°C
<14°F	±6°F

\* Ambient temperature 23 ± 2°C and calibration geometry

Temperature coefficient: ±0.1°C/°C or ±0.1%/°C of reading (whichever is greater)

Repeatability: ±1.0°C (2.0°F) or ±8% of reading (whichever is greater)

Response time: <125ms to 95% of reading

Spectral response: 8 to 14 microns

Emissivity settings: 0.95, 0.80, 0.60, 0.30, or variable from 0.10 to 0.99

Distance spot ratio: 30:1



Specification  
IRC327 Advanced  
Thermal Camera

**Thermal Imaging Detector**

Type: IR-EX™ Technology (Integrated IR Array Sensor with CMOS Sensor)

Imaging resolution: 16,384 pixels (128 x 128 pixels)\*

Field of view (H x W): 33°

Upper sense range: 650°C

Thermal imaging sensitivity: 150mK

Colour palette: Greyscale, Hot iron, Rainbow

\* Interpolation pixels

**GENERAL**

Display: 4.5cm colour TFT (128 x 160 pixels)

Laser: Laser product class: 2

Rated wavelength: 650nm

Beam divergence: 1mrad max.

Output power: 1mW max.

Micro SD card: 2 GB card fitted, maximum card size 32GB

Power: 3 x 1.5V, AA alkaline batteries (IEC LR6, NEDA 15A)

Battery Life: 12 hours typical

Auto power off: settable to 1, 2, 5 or 10 minutes

Low battery indication: The low battery symbol is displayed when the battery voltage drops below the operating level

Dimensions: 185 x 54 x 104 mm

Weight: Approx. 300g including batteries

Includes: 3 x 1.5V AA batteries, 2GB micro SD card and instructions



Specification  
IRC327 Advanced  
Thermal Camera

**ENVIRONMENTAL**

Operating environment: -10 to 50°C at <70% R.H.

10 to 90% R.H. non-condensing at 30°C

Storage environment: -20 to 60°C, with batteries removed.

Altitude: up to 2000m (Operating)

up to 12000m (Storage)

**SAFETY**

Conforms to: BS EN 61010-1

Class II, double insulation

BS EN 60825-1:2014 for Class 2 Laser products

**EMC**

Conforms to BS EN 61326-1

**Check out what else you can get from Martindale:**

- 18th Edition Testers
- Accessories
- Calibration Equipment
- Continuity Testers
- Electricians' Kits
- Environmental Products
- Full Calibration & Repair Service
- Fuse Finders
- Digital Clamp Meters
- Digital Multimeters
- Labels
- Microwave Leakage Detectors
- Motor Maintenance Equipment
- Multifunction Testers
- Non-trip Loop Testers
- Pat Testers & Accessories
- Phase Rotation Testers
- Proving Units
- Socket Testers
- Thermometers & Probes
- Test Leads
- Voltage Indicators
- Specialist Metrohm Testers (4 & 5kV)
- Specialist Drummond Testers



Martindale Electric Company Limited  
Tel: +44(0)1923 441717 Fax: +44 (0)1923 446900  
E-mail: sales@martindale-electric.co.uk  
Website: www.martindale-electric.co.uk

© Martindale Electric Company Ltd. 2018  
Registered in England No. 3387451. Rev 3 LIT327

